

Installation and Operation Manual

Legacy™ Pool and Spa Heater

Model LRZ Millivolt Natural Gas or LPG

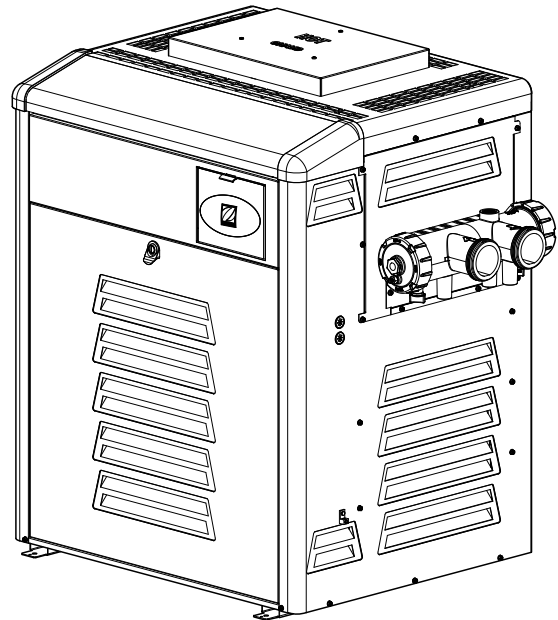

WARNING

If these instructions are not followed exactly, a fire or explosion may result, causing property damage, personal injury, or death.

FOR YOUR SAFETY: This product must be installed and serviced by a contractor who is gas safe registered and HWB1 certified. Before installing this product, read and follow all warning notices and instructions that accompany this product. Failure to follow warning notices and instructions may result in property damage, personal injury, or death. Improper installation and/or operation can create carbon monoxide gas and flue gases which can cause serious injury, property damage, or death. For indoor installations, as an additional measure of safety, Zodiac Pool Systems, Inc. strongly recommends installation of suitable Carbon Monoxide detectors in the vicinity of this appliance and in any adjacent occupied spaces. Improper installation and/or operation will void the warranty.

WARNING

Read this manual in its entirety. If these instructions are not followed exactly, a fire or explosion may result, causing property damage, personal injury, or death.

The GAS SAFETY (INSTALLATION AND USE) REGULATIONS 1998 as amended, place statutory requirements on gas users.

This heater is certified to European requirements for use only as a swimming pool or spa heater. The heater must not be used for any other purpose and must be installed and serviced by a qualified professional. The heater must be operated strictly in accordance with the user's instructions and applicable laws.

If the heater is installed in a room, it must be separated from a living space, and adequate air supply and ventilation must be provided and maintained.

Do not store or use gasoline or other flammable vapors and liquids in the vicinity of this or any other appliance.

Table of Contents

Section 1. General Information	5	Section 5. Water Connections	14
1.1 Introduction.....	5	5.1 Water Piping	14
1.2 Consumer Information and Safety.....	5	5.2 Hydraulic Head Loss	14
1.2.1 Spa/Hot Tub Safety Rules	5	5.3 Check Valve Installation	14
1.2.2 Swimming Pool Energy Saving Tips	6	5.4 Automatic Flow Control Valve	14
1.3 Warranty.....	6	5.5 Reversible Water Connections	15
1.4 Codes and Standards.....	6	5.6 Connections at Heater.....	17
1.5 Technical Assistance	6	5.7 Pressure Relief Valve	17
1.6 Materials Installer Must Provide	6	5.8 Auxiliary Components, Chlorinators, Ozone Generators, and Sanitizing Chemicals	19
1.6.1 Materials for All Applications	6	Section 6. Electrical.....	19
1.6.2 Materials for Special Applications.....	6	6.1 Main Power	19
1.7 Specifications	7	6.2 Earth Bonding.....	19
1.7.1 General Specifications.....	7	6.3 Auxiliary Time Clock Wiring.....	20
1.7.2 Performance Specifications.....	7	Section 7. Commissioning.....	21
1.7.3 Dimensions	7	7.1 Heater Start-Up	21
Section 2. Installation Instructions	7	Section 8. Operating Instructions	21
2.1 Introduction.....	7	8.1 Normal Operation	21
2.2 Statutory Information	8	8.2 Start-Up	22
2.3 General Installation Requirements	9	8.3 Lighting and Shutdown Procedures	22
2.4 Field Assembly	9	8.3.1 Lighting the Heater	22
2.5 Location Requirements	9	8.3.2 Relighting the Heater.....	24
2.5.1 Introduction	9	8.3.3 Shut-Down Procedure	24
2.5.2 Clearances	9	8.4 Turning the Heater On/Off and Setting the Temperature Control	24
2.5.3 Flooring.....	10	Section 9. Maintenance.....	25
2.5.4 Outdoor Installation	10	9.1 Water Chemistry.....	25
2.5.5 Indoor for Natural Gas Installation Only	11	9.2 Seasonal Care.....	25
Section 3. Venting.....	11	9.2.1 Spring and Fall Operation.....	25
3.1 Combustion Air Supply	11	9.2.2 Winterizing	25
3.2 Flue System Type B11 (Indoor).....	11	9.2.3 Spring Start-up	26
3.3 Vent Pipe Sizing and General Installation	12	9.3 Inspection and Service	26
3.3.1 Outdoor Installations.....	12	9.3.1 Owner Inspection.....	26
3.3.2 Indoor Installations (Natural Gas ONLY) ..	12	9.3.2 Professional Inspection	26
3.3.3 Inspection and Replacement of Existing Vent System with New Components	13	Section 10. Troubleshooting	28
Section 4. Gas Connections	13	10.1 General Heater Troubleshooting	28
4.1 Gas Supply and Piping.....	13		
4.2 Burner Pressure	14		
4.3 Special Precautions for LPG	14		

Table of Contents (Continued)

Section 11. Professional Maintenance and Service	30
11.1 General Information.....	30
11.2 Natural-Draft Combustion System.....	30
11.3 Heater Components and Their Operation	30
11.4 Electrical Troubleshooting	31
11.4.1 Gas Valve	31
11.4.2 Pilot Generator	33
11.4.3 Fusible Link	33
11.4.4 Fireman Switch and External Interlocks	33
11.4.5 Limit Switches.....	34
11.4.6 Water Pressure Switch	34
11.4.7 Temperature Control Circuit.....	34
11.4.7.1 ON/OFF Toggle Switch	34
11.5 Adjusting the Water Pressure Switch	35
11.6 Temperature Rise	35
Section 12. Replacement Parts	36
12.1 Ordering Information	36
12.2 Parts List	37
12.3 General Exploded View	38
12.4 Detailed Exploded View	39

Section 1. General Information

1.1 Introduction

This manual provides installation and operation instructions for the Legacy Model LRZ millivolt pool and spa heaters. Read these installation and operation instructions completely before proceeding with the installation. The installation must be conducted by a qualified professional. While the entire manual should be read by both the qualified professional installer and the user, Sections 2 through 7 of this manual are intended for the qualified professional installer. The Operating instructions for the user begin in Section 8. Consult the Zodiac factory, or local factory representative, with any questions regarding this equipment. The instructions cover two (2) types of heaters as follows:

1. Type A (flueless) for outdoor installations only.
2. Type B11 flue for outdoor and indoor installations, but must not be installed in a living space.

The Legacy model LRZ millivolt heater is a self contained standing pilot unit and requires no external power.

The Legacy Model LRZ millivolt heater is specifically designed for heating fresh water swimming pools and spas, and with proper installation and care, will provide years of reliable service. Do not use the heater to maintain pool or spa water temperature below 21°C (70°F). Do not use it as a heating boiler or general service water heater. Consult your dealer for the appropriate Zodiac products for these applications.

NOTE "Fresh water swimming pools and spas" include systems that utilize saltwater chlorine generator units, such as the Jandy AquaPure® Electronic Chlorine Generator. Please ensure that the salt content of the pool/spa *does not exceed* 4000 ppm and water flow rate is within 110-470 lpm.

1.2 Consumer Information and Safety

The Legacy Model LRZ millivolt heater is designed and manufactured to provide many years of safe and reliable service when installed, operated and maintained according to the information in this manual and the installation codes referred to in later sections. Throughout the manual safety warnings and cautions are identified by the "▲" symbol. Be sure to read and comply with all of the warnings and cautions.

1.2.1 Spa/Hot Tub Safety Rules

▲ WARNING

Elevated water temperature can be hazardous. Consult heater operation and installation instructions for water temperature guidelines before setting temperature.

1. Spa or hot tub water temperature should never exceed 40°C (104°F). Thirty-eight degrees Celsius (38°C [100°F]) is considered safe for a healthy adult. Special caution is recommended for young children.
2. The drinking of alcoholic beverages before or during spa or hot tub use can cause drowsiness which could lead to unconsciousness, and subsequently result in drowning.
3. **Pregnant women take note!** Soaking in water above 38.5°C (102°F) can cause fetal damage during the first three (3) months of pregnancy (which could result in the birth of a brain-damaged or deformed child). If pregnant women are going to use a spa or hot tub, they should make sure the water temperature is below 38°C (100°F) maximum.
4. The water temperature should always be checked with an accurate thermometer before entering a spa or hot tub. Temperature controls may vary by as much as 1°C (1°F).
5. Persons with a medical history of heart disease, diabetes, circulatory or blood pressure problems should consult their physician before using a hot tub or spa.
6. Persons taking any medication which induces drowsiness (e.g., tranquilizers, antihistamines, or anticoagulants) should not use spas or hot tubs.
7. This appliance is not intended for use by persons (including children) with reduced physical, sensory or mental capabilities, or lack of experience and knowledge, unless they have been given supervision or instruction concerning use of appliance by a person responsible for their safety. Children should be supervised to ensure that they do not play with the appliance.
8. Prolonged immersion in hot water can induce hyperthermia.

Hyperthermia occurs when the internal body temperature reaches a level several degrees above the normal body temperature of 37°C (98.6°F). Symptoms include dizziness, fainting, drowsiness, lethargy, and an increase in the internal body temperature. The effects of hyperthermia include:

- Lack of awareness of impending hazard
- Failure to perceive heat
- Failure to recognize need to leave spa
- Physical inability to leave spa
- Fetal damage in pregnant women
- Unconsciousness resulting in a danger of drowning

1.2.2 Swimming Pool Energy Saving Tips

Zodiac Pool Systems, Inc., ("Zodiac") offers the following recommendations to help conserve fuel and minimize the cost of operating your pool heater without sacrificing comfort.

1. The American Red Cross recommends a maximum water temperature of 25°C (78°F). Use an accurate pool thermometer. A difference of 2°C (4°F), between 26°C and 28°C (78°F and 82°F), will use as much as 40% more gas.
2. Carefully monitor the water temperature of your pool in the summertime. You can reduce heater usage due to warmer air temperatures.
3. Find the proper setting on the pool heater temperature control and use the Set Point Lockout feature to discourage further adjustments.
4. Set the pump time clock to start the pump no earlier than 6:00 AM during the pool heating season. This is the time when nightly heat loss balances.
5. If the pool is only going to be used on weekends, reduce the heater temperature control setting by 8 or 10 degrees during the week. Reset it to the 25°C (78°F) level a day or so before you plan to use the pool.
6. During the winter or when on vacation for longer than a week, shut down the heater by following the shutdown instructions found on the inside of the heater.
7. Where possible, shelter the pool from prevailing winds with well-trimmed hedges or other landscaping, cabanas, or fencing.
8. Always use a pool cover when practical. Besides providing a valuable safety feature, a pool cover will reduce heat loss, conserve chemicals, and reduce the load on filter systems.

1.3 Warranty

The Legacy Model LRZ millivolt heater is sold with a limited factory warranty. Details are specified on the back cover of this manual.

Make all warranty claims to an authorized Zodiac representative or directly to the factory. Claims must include the heater serial number and model (this information can be found on the rating plate), installation date, and name of the installer. Shipping costs are not included in the warranty coverage.

The warranty does NOT cover damage caused by improper assembly, installation, operation or field modification. Also, damage to the heat exchanger by corrosive water is NOT covered by the warranty. See Section 9.1 for maintaining proper pool water chemistry.

NOTE Keep this manual in a safe place for future reference when inspecting or servicing the heater.

1.4 Codes and Standards

The Legacy Model LRZ millivolt heater has been tested and certified by GL Industrial Services for compliance with the Gas Appliance Directive (GAD; 2009/142/EC) and the latest version of European Standard, BSEN 656. In addition, the product has also been found to be in compliance with the essential requirements of the Low Voltage Directive (LVD; 2006/95/EC), and the Electromagnetic Compatibility Directive (EMC Directive; 2004/108/EC).

All Zodiac heaters must be installed in accordance with the local building and installation codes as per the utility or authorities having jurisdiction.

Any changes to the heater, gas controls, gas orifices, wiring, draft hood, vent cap, or improper installation may void the warranty. If change is required to any of the above, consult the factory.

1.5 Technical Assistance

Consult your local Zodiac distributor with any questions or problems involving the specifications, installation, and operation of your Zodiac equipment.

1.6 Materials Installer Must Provide

1.6.1 Materials for All Applications

The following items are needed and are to be supplied by the installer for *all* Legacy Model LRZ millivolt heater installations:

1. The correct size gas pipe to supply gas from the meter to the heater (see Section 4.1).
2. A manually operated gas cock to be installed in the gas line outside of the heater jacket.
3. Plumbing items needed to provide a sediment trap (drip leg) in the gas line between the manual gas cock and the heater (see Section 4.1).

1.6.2 Materials for Special Applications

In addition to the items listed above, the following items are needed for special applications:

1. A factory authorized draft hood and any vent pipe needed for indoor installations. See Section 3.3.2. Draft hoods are available from any Zodiac distributor.
2. Primer and cement suitable for cementing PVC pipe to the CPVC Zodiac unions supplied with the heater.

3. A noncombustible platform for installation on combustible surfaces (see Section 2.5.3). Noncombustible bases are available from your Zodiac distributor.
4. A factory approved vent cap for all outdoor installations where wind conditions may cause downdrafting. Approved vent caps are available from your Zodiac distributor. See Section 12.2, "Parts List", of this manual for the correct part number.

1.7 Specifications

1.7.1 General Specifications

1. Installation Location:
 Certified for use:
 Natural Gas: Indoor and Outdoor
 LPG: Outdoor Only
 Refer to Table 1.
2. Minimum Clearance From Combustible Material
 See Table 4.

1.7.2 Performance Specifications

The Legacy Model LRZ millivolt heater performance specifications are shown in Table 2.

1.7.3 Dimensions

See Figure 1 for a diagram showing the heater's exterior dimensions and dimensions to critical connections on the heater.

Section 2. Installation Instructions

2.1 Introduction

WARNING

This product must be installed and serviced by a contractor who is licensed and qualified in pool equipment. Improper installation or maintenance can cause nausea or asphyxiation from carbon monoxide in flue gases which could result in severe injury, or death. For indoor installations, as an additional measure of safety, Zodiac strongly recommends installation of suitable Carbon Monoxide detectors in the vicinity of this appliance and in any adjacent occupied spaces. The heater may only be installed in a room which complies with the appropriate ventilation requirements and which is separate from living areas.

Install the Legacy Model LRZ millivolt heater, vent caps and draft hoods in accordance with the procedures in this manual, local codes and ordinances, and in accordance with the latest edition of the appropriate national code (see Section 1.4 "Codes and Standards").

All gas-fired products require correct installation to assure safe operation. The requirements for pool heaters include the following:

1. Field assembly (if required)
2. Appropriate site location (clearances) and flooring
3. Sufficient combustion and ventilation air
4. Properly sized gas meter and piping

Table 1. General Specifications

	LRZ				
	125	175	250	325	400
Water Capacity (L)	0,81	0,95	1,16	1,35	1,57
Minimum Water Flow (l/min)	75,7	75,7	94,6	113,6	113,6
Maximum Static Head (bar)	5,1	5,1	5,1	5,1	5,1
Maximum Outlet Temp (C)	40	40	40	40	40
Dry Weight (kg)	60	67	78	88	100
Gas Connection	3/4 in Bsp (Rc 3/4)	3/4 in Bsp (Rc 3/4)	3/4 in Bsp (Rc 3/4)	3/4 in Bsp (Rc 3/4)	3/4 in Bsp (Rc 3/4)
Water Inlet Connection	2" unthreaded PVC or CPVC	2" unthreaded PVC or CPVC	2" unthreaded PVC or CPVC	2" unthreaded PVC or CPVC	2" unthreaded PVC or CPVC
Water Outlet Connection	2" unthreaded PVC or CPVC	2" unthreaded PVC or CPVC	2" unthreaded PVC or CPVC	2" unthreaded PVC or CPVC	2" unthreaded PVC or CPVC
Electrical Supply	220-240VAC, 50 Hz, 5 Amps Max	220-240VAC, 50 Hz, 5 Amps Max	220-240VAC, 50 Hz, 5 Amps Max	220-240VAC, 50 Hz, 5 Amps Max	220-240VAC, 50 Hz, 5 Amps Max
IP Rating	IPX4				
Flue Types	Flue Type A (Flueless) for Outdoor Installations Only Flue Type B11 (with Vent Cap for High Wind Areas) For Outdoor Installation Only Flue Type B11 (with Draft Hood) for Indoor Installation Only				
Appliance Category:					
Natural Gas	I2H				
LPG	I3P				
Inlet Pressure (mbar)					
Natural Gas	G20				
LPG	G31 @ 37 mbar				
Note: The LPG heat inputs apply up to an altitude of 600 m. Above this altitude, de-rate the heat input by 4% for every 300 m.					

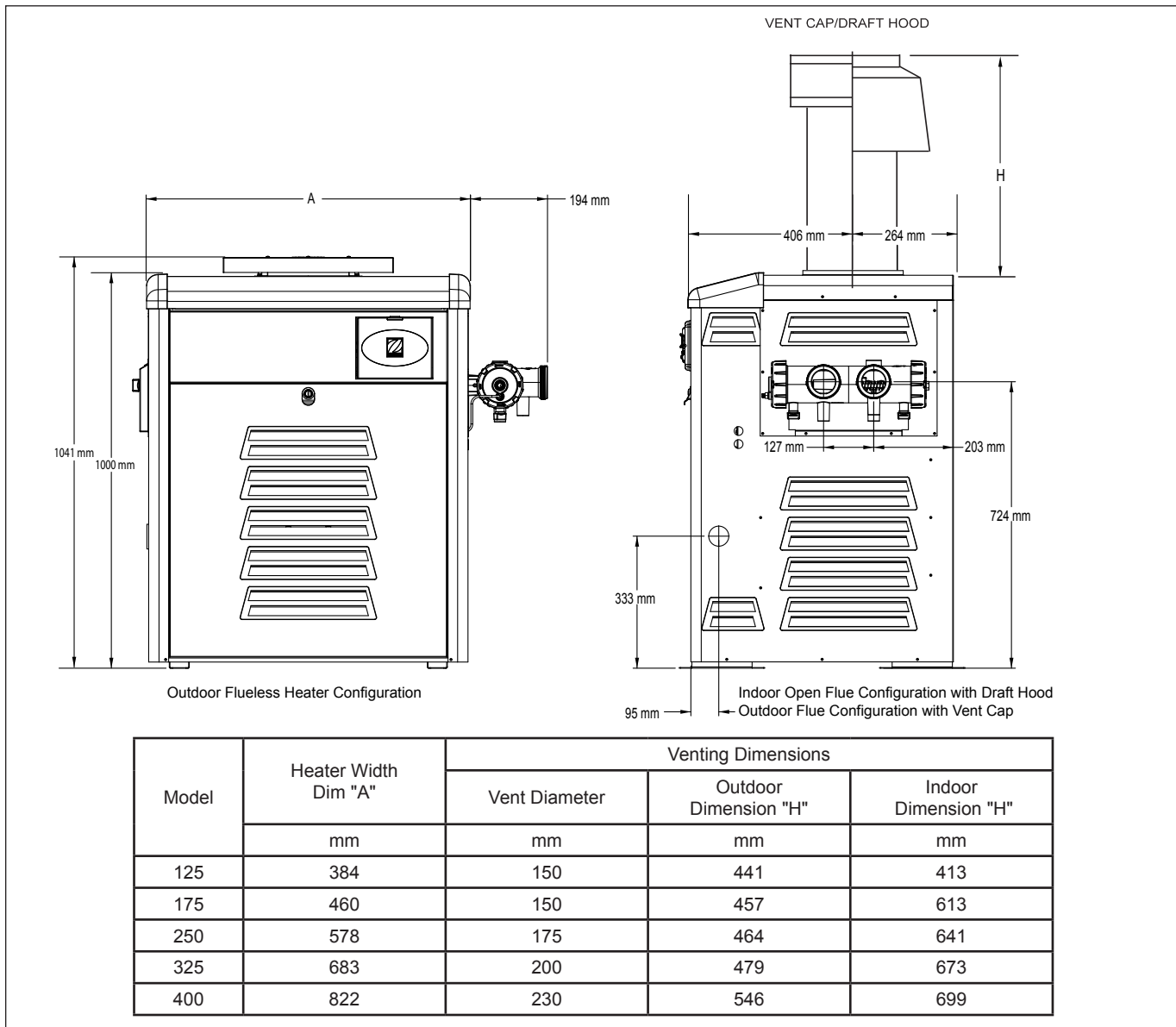

Figure 1. General Configuration

5. Proper electrical wiring (if required)
6. Adequate water flow

This manual provides the information needed to meet these requirements. Review all application and installation procedures completely before continuing the installation.

2.2. Statutory Information

It is the law that all gas appliances are to be installed only by competent persons (e.g., registered members of Gas Safe) in accordance with the Gas Safety (Installation and Use) Regulations, latest published version of BS6798, BS5440 Pt. 1 and Pt. 2, BS6891, and BS5482 Pt. 2. Failure to install appliances correctly could lead to prosecution.

The Legacy heater, as supplied, has been tested and certified by Gas Appliance Directive (GAD; 2009/142/EC) and the latest version of European Standard, BSEN 656 for use with natural and LPG gases. Legacy heaters are only permitted to be installed

in the open air or in a room which is separated from living rooms and provided with appropriate ventilation directly to the outside.

⚠ WARNING

The Legacy heater is certified to European requirements for use only as a swimming pool or spa heater. The Legacy heater must not be used for any other purpose and must be installed and serviced by a qualified professional. The Legacy heater must be operated strictly in accordance with the manufacturer's instructions. If the Legacy heater is installed in a room, adequate air supply and ventilation must be provided and maintained. Never store any materials within the area of the heater or ventilation openings.

It is important that no external control devices (e.g., flue dampers, economizers, etc.) be directly connected to the Legacy heater unless covered by these installation and servicing instructions or other-

Table 2. LRZ M Performance Specifications

	LRZ M Size (In BTU Input)									
	125 BTU		175 BTU		250 BTU		325 BTU		400 BTU	
	Nat. Gas	LPG	Nat. Gas	LPG	Nat. Gas	LPG	Nat. Gas	LPG	Nat. Gas	LPG
Heat Input Gross (kW)	40,7	40,7	56,9	56,9	81,5	81,5	105,9	105,9	130,3	130,3
Heat Input Net (kW)	36,7	36,7	51,3	51,3	73,4	73,4	95,4	95,4	117,4	117,4
Heat Output (kW)	28,6	28,6	41,1	41,1	58,7	58,7	76,8	76,8	95,1	95,1
Max. Burner Pressure (mbar)	9	22,4	9	22,4	9	22,4	9	22,4	9	22,4
Gas Rate (m ³ /h) G20	3,5	--	4,9	--	7	--	9,1	--	11,2	--
Gas Rate (m ³ /h) G30	--	1,05	--	1,48	--	2,3	--	2,99	--	3,47
Flue Gas Volume 4.5% CO ₂ , 120C (l/sec)	32,1	--	44,9	--	64,1	--	83,9	--	102,8	--
Flue Gas Volume 4.5% CO ₂ , 120C (l/sec) G30	--	32,3	--	45,3	--	70,3	--	91,4	--	106,4
Injector Diameter (mm and marking)	(2,26) Marked 43	(1,51) Marked 53	(2,26) Marked 43	(1,51) Marked 53	(2,26) Marked 43	(1,51) Marked 53	(2,26) Marked 43	(1,51) Marked 53	(2,26) Marked 43	(1,51) Marked 53

wise recommended in writing by Zodiac, if in doubt please ask. Any direct connection of a control device not approved by Zodiac, could invalidate the Gas Appliance Directive (GAD) certification, the normal Legacy heater warranty, and could also violate applicable gas safety regulations.

2.3 General Installation Requirements

The Legacy heater must be installed by competent persons (e.g., registered member of Safe Gas). The Legacy heater must be installed in accordance with the relevant requirements of the Gas Safety Regulations, current I.E.E. Regulations, Model Water Bylaws, local Water Authority Bylaws, and any relevant requirements of local gas region, local authority, and relevant British Standard Codes of Practice and Building Regulations.

2.4 Field Assembly

The Legacy Model LRZ millivolt heater is shipped from the factory with the top assembly in the low-profile flueless Type A configuration for outdoor installation. The Legacy Model LRZ millivolt heater is design certified for indoor installation when equipped with a draft hood and Type B11 flue, which must be installed without modification.

Check the rating plate on the heater or the Parts List (Section 12) of this manual for the correct Zodiac draft hood or vent cap part number. See instructions supplied with the draft hood or vent cap for installation and attachment. When the draft hood is used, locate the heater so as to be in the same atmospheric pressure zone as the combustion air inlet to the heater.

2.5 Location Requirements

2.5.1 Introduction

CAUTION

When pool equipment is located below the pool surface, a leak from any component can cause large scale water loss or flooding. Zodiac cannot be responsible for such water loss or flooding or resulting damage.

The Legacy Model LRZ millivolt heater may be installed indoors or outdoors as outlined in later sections. Location of the heater below *or above* the pool water level affects operation of its water pressure switch. See sections on water piping and heater start-up for more information about this.

Avoid placing the heater in locations where it can cause damage by water or condensate leakage. If this is not possible, provide a suitable drain pan to catch and divert any leakage. The pan must not restrict the air flow around the heater.

All criteria given in the following sections reflect minimum clearances as stated in the national standards. However, each installation must also be evaluated, taking into account the prevailing local conditions such as wind speed and direction, proximity and height of walls that may block ventilation, and proximity to public access areas.

2.5.2 Clearances

The heater must be placed to provide clearances on all sides for maintenance and inspection. There must also be minimum distances maintained from combustible surfaces (see Table 3).

At least 457 mm access must be available in front of the heater for burner removal and access to the igniter.

If the heater is to be installed in a garage, or similar structure, all burners and burner ignition devices must have a minimum 457 mm clearance above the floor.

This heater must be installed at least 1.52 m from the inside wall of a pool unless the heater is separated from the pool by a solid fence, wall or other permanent solid barrier.

2.5.3 Flooring

The heater must be installed on a **level** surface of noncombustible construction or on fire-resistant slabs or arches. Noncombustible flooring is defined as flooring material and surface finish not capable of being ignited and burning and with no combustible materials against the underside. Acceptable materials are those consisting entirely of a combination of steel, iron, brick, tile, concrete, slate, glass or plaster. **Do not** install the heater directly on a combustible wood or carpet floor without placing a noncombustible platform between the floor and the heater.

The heater can be installed on a combustible floor if a noncombustible base assembly, available from Zodiac, is used. See the heater rating plate or the Parts List (Section 12) of this manual for the appropriate base part number. **Heaters must never be installed directly on carpeting.**

As an alternative to the Zodiac noncombustible base plate, the heater may be placed on a combustible surface when there is a platform under the heater made of hollow masonry no less than 102 mm thick, covered with sheet metal at least 24 gauge thick and extending beyond the full width and depth of the heater by at least 153 mm in all directions. The masonry must be laid with ends unsealed, and joints matched to provide free circulation of air from side to side through the masonry (see Figure 2). If the heater is installed in a carpeted alcove, the entire floor of the alcove must be covered by a noncombustible panel.

Table 3. Minimum Heater Clearances From Combustible Surfaces

SIDE OF HEATER	MINIMUM CLEARANCE
	Millimeters
BLANK	203
REAR	150
PIPING	355
TOP	1120
FRONT	457

Note: Clearances listed in Table 4 are manufacturer's tested values. These are given as minimum values. Where local codes apply, and values are different than those listed in Table 4, use the greater value to ensure safe operation.

2.5.4 Outdoor Installation

The Legacy Model LRZ millivolt heater can be installed in the low-profile Type A flueless configuration as received from the factory. Alternately, the heater may be installed outdoors using a Type B11 vent cap. This vent cap is used in high wind installations. No draft hood is required for this type of outdoor installation.

Locate the heater in an **open, unroofed area**. Do not install the heater under a deck. Do not locate the heater below or adjacent to any doors, glass openings, louvers, grills, etc., which connect in any way with an inhabited area of a building, even though the access might be through another structure (e.g., a garage or utility room). There must be a minimum of 2 m horizontally or 2 m vertically between the heater and any door, glass opening, or gravity inlet into a building. See Figure 3.

The top surface of the heater must be at least 0.91 m above any forced air inlet, or intake ducts located within 3.0 m horizontally.

If the heater is installed under an overhang, there must be a minimum clearance of 1.5 m above the top of the heater and the structure should not overhang the heater more than 0.30 m. The area under the overhang must be open on three (3) sides. This prevents combustion gases from being diverted into living areas through doors, windows, or gravity inlets.

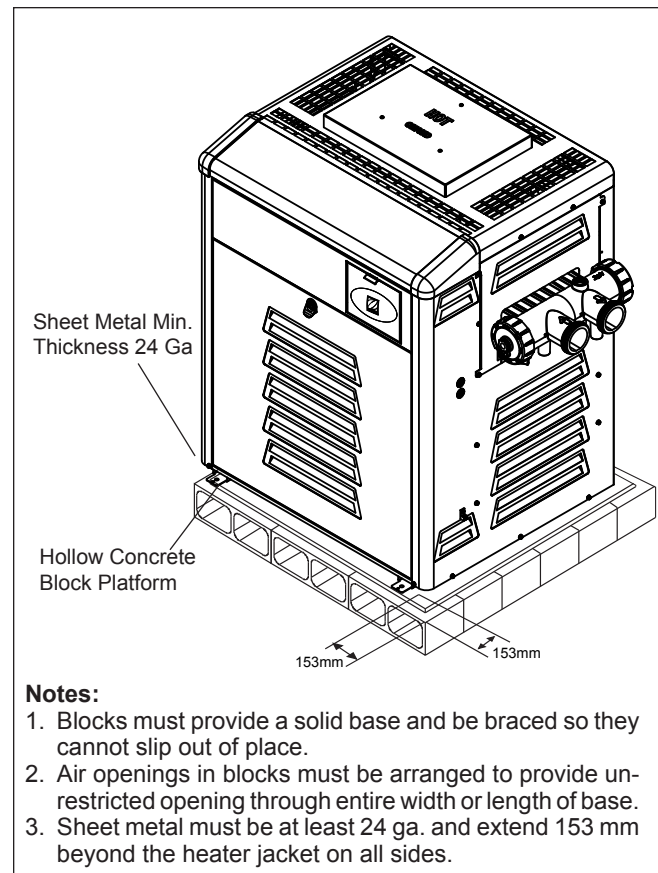

Figure 2. Noncombustible Platform

If the heater is installed close to a structure, protect it from rain water runoff with rain gutters on the roof or other measures. Do not locate the heater near irrigation sprinkler systems that could spray water on it. Water from sprinklers may cause damage to controls and electronic components.

Avoid locations where wind deflection off nearby structures might cause downdraft conditions. Where downdraft conditions exist, locate the heater at least 0.91 m from vertical surfaces (e.g., nearby buildings and walls).

2.5.5 Indoor for Natural Gas Installation Only

The Legacy heater can be installed indoors using the draft diverter available from Zodiac, and a Type B11 flue system complying with the national and local applicable standards in addition to the Building Regulations (see Section 2).

Section 3. Venting

The applicable codes, standards and Zodiac, require that the heater be properly vented as outlined in this manual. Proper ventilation of exhaust and combustion air are essential for the safe and efficient operation of the heater.

3.1 Combustion Air Supply

The heater location must provide sufficient air supply for proper combustion and ventilation of the surrounding area.

In general, the room in which a heater is installed should be provided with two (2) permanent air supply openings; one within 305 mm of the ceiling, the other within 305 mm of the floor. All indoor installations must have uninterrupted openings to outside air for combustion, ventilation, and dilution of flue gases from inside the building (see Figure 4 and Table 4). Zodiac, does not recommend indoor installations that do not provide combustion air from outside the building.

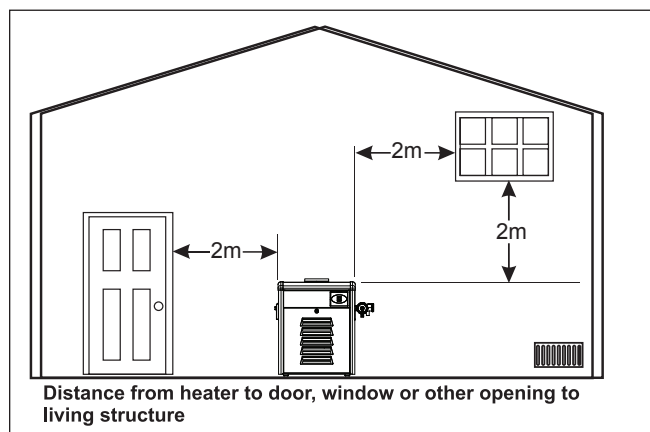

Figure 3. Outdoor Heater Installation

Table 4. Ventilation Requirements

Positions of Air Vents	Air Vent Areas (Air Direct From Outside)
High Level	270 cm ² plus 2.25 cm ² per kW in excess of 60 kW total rated input
Low Level	540 cm ² plus 4.5 cm ² per kW in excess of 60 kW total rated input

Exhaust Fans or Vents: Any equipment which exhausts air from the room where the heater is installed can deplete the combustion air supply or reverse the natural draft action of the venting system. This could cause flue products to accumulate in the room. Additional air must be supplied to compensate for such exhaust.

The information in Table 3 is not applicable in installations where exhaust fans or blowers of any type are used. Such installations must be designed by qualified engineers.

The heater must be completely isolated and protected from any source of corrosive chemical fumes such as those emitted by trichlorethylene, perchloroethylene, chlorine, etc.

⚠ WARNING

Do not store any chemicals, cleaners, or other corrosive material near combustion air openings or in the room. Avoid locating appliance vents in the vicinity of combustion air openings. Failure to prevent corrosive materials from mixing with combustion air can result in reduced heater life and unsafe heater operation.

3.2 Flue System Type B11 (Indoor)

Connect the draft diverter to a Type B11 flue system of at least the same diameter, and end at least 0.6 meters above the highest point of the roof or other object that is within 3.05 m of the vent. Install a certified terminal which allows a full equivalent opening for flue products (see Figure 4). There must be at least 600 mm of vertical flue above the drafthood. Bends in the flue should not exceed 45° to the vertical.

To make sure the heater operates safely and satisfactorily, the flue system must be able to completely remove combustion products at all times. The number of bends and lengths of horizontal flue pipe used should be kept to a minimum in order to reduce gas flow resistance.

Compliance with all national and local applicable installation codes and regulations should be strictly observed.

The flue design should avoid the formation of excessive quantities of condensate. For this reason, it is recommended that all flues be insulated and lined. For brick or similar structures, a stainless steel rigid or flexible flue liner (Grade 304/316) may be used in conjunction with a 50 mm (minimum) thick layer or

vermiculite or perlite granules between the liner and the inner skin of the chimney body.

Liners should be sealed at both top and bottom. Drainage points should be provided at the bottom of all vertical flue sections. Drain pipes should be:

1. No less than 25 mm inside diameter.
2. Made from acid condensate resistant material (e.g., stainless steel).
3. Positioned so that pipe runs and discharge points are not subject to the effects of frost and flue gases cannot leak into the boiler room.

3.3 Vent Pipe Sizing and General Installation

3.3.1 Outdoor Installations

For outdoor installations, exhaust venting considerations will determine the placement of the heater (See Section 2.5.4). If the heater cannot be placed so as to meet the requirements stated in Section 2.5.4, a Type B11 vent pipe and cap may be added to the heater to move the exhaust vent opening to a position that complies with the requirements. When the heater is installed in areas of high wind or when unavoidably installed near a vertical obstruction where downdrafting may occur, it may be desirable to add a vent cap directly to the top of the heater. In all cases, vent pipes and caps must be of the same diameter as the exhaust outlet of the heater. Approved vent caps may be obtained through your Zodiac distributor.

3.3.2 Indoor Installations (Natural Gas ONLY)

⚠ WARNING

Vent pipe diameter must be as required by applicable local gas appliance installation codes such as BS 5440. Undersized pipe can result in inadequate venting and oversized pipe can result in vent condensation. In either case the result can be release of combustion products to the indoors. This can cause serious injury or death by carbon monoxide poisoning or asphyxiation.

All indoor installations and outdoor shelter installations require a factory approved draft hood and Type B11 venting. The draft hood must be installed without modification. All vent installations must be made in accordance with all local, state or provincial codes and with:

Avoid long horizontal runs of the vent pipe, and 90° elbows, reductions and restrictions. Horizontal runs should have at least a 20 mm rise per meter in the direction of flow.

Avoid terminating heater vents near air conditioning or air supply fans. The fans can pick up exhaust flue products from the heater and return them inside the building, creating a possible health hazard.

Do not locate the vent terminal where flue products could strike against building materials and cause degradation.

Vent opening should be well away from trees or other obstructions that would prevent free air flow to and from vent terminal. Do not terminate the vent under decks, stairways, or car ports.

Be sure to support all venting so that connections will not separate and so that the weight of the vent pipe does not rest on the heater draft hood. All connections should be made with rustproof sheet metal screws. Do not weld or fasten the vent pipe to the heater draft hood. The draft hood and heater top must be easily removable for normal heater service and inspection.

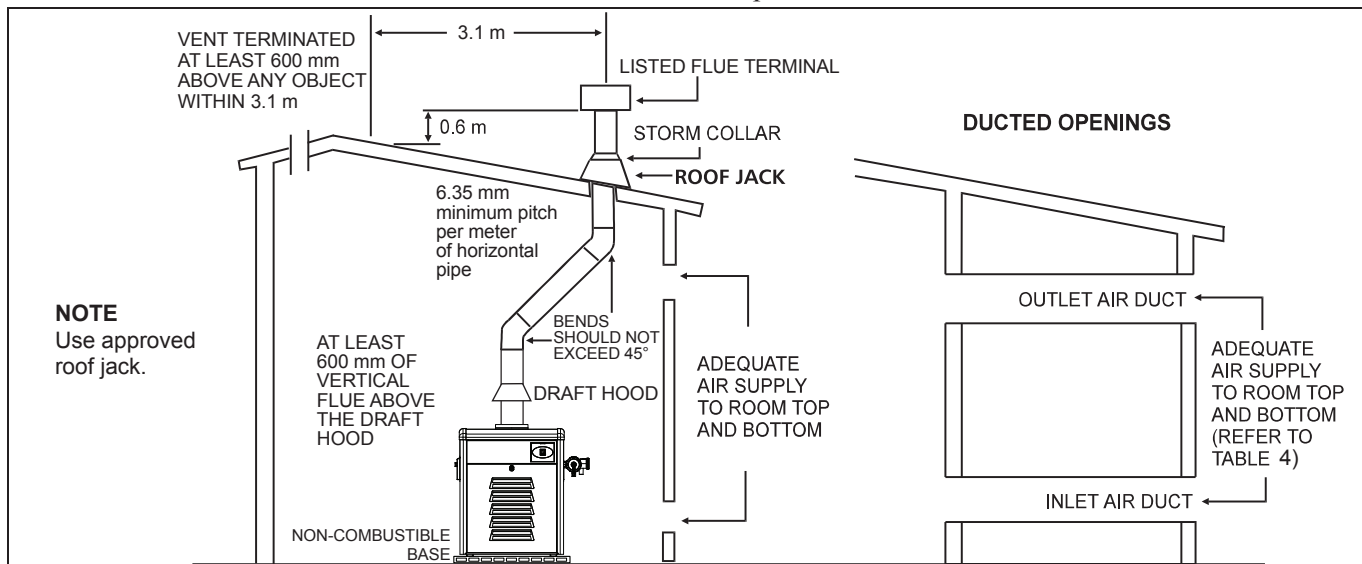

Figure 4. Indoor Installation Venting or Outdoor Shelter Venting

The draft hood outlet is to be connected to an unobstructed vent pipe of the same diameter, terminating outside the building. The vent must terminate at least 0.6 m above the highest point of the roof or other object that is within 3.05 m of the vent termination. The vent pipe must have a listed vent cap which allows a full equivalent opening for flue products (see Figure 4). The top of the vent cap must be at least five (5) feet in vertical height above the draft hood outlet.

Double wall or equivalent vent pipe is recommended.

IMPORTANT NOTE: Do not use sheet metal screws at the snap lock joints of gas vents.

When venting multiple appliances through one common duct, each appliance must have its own vent temperature limit switch. All vent limit switches must be wired in series so as to prevent any appliance from firing in the event of a blocked vent. Refer to national and local installation codes for more information on multiple venting.

3.3.3 Inspection and Replacement of Existing Vent System with New Components

If the Legacy heater is being installed to replace an existing pool heater, it is recommended that a new appropriate venting system be installed with the new heater. However, if an existing venting system must be used, be sure to carefully inspect the venting system to ensure that it is in good condition and continues to be appropriate for the Legacy heater. Replace any parts that are not in good and serviceable condition with new parts before completing the pool heater installation.

Section 4. Gas Connections

4.1 Gas Supply and Piping

Review the following general instructions before continuing the installation.

<p>⚠ WARNING</p> <p>The Legacy Model LRZ pool and spa heaters are designed for use with either natural gas or LPG. Check the rating plate on the inner panel to be sure that the heater is designed to use the type of gas being supplied. DO NOT ATTEMPT TO CONVERT THIS HEATER FOR USE WITH ANY OTHER TYPE OF FUEL.</p>
<p>⚠ CAUTION</p> <p>Permanent damage to the gas valve will occur if the following procedures are not followed.</p>

- Gas piping installation must be in accordance with all applicable local rules and regulations

such as "The Gas Safety (Installation and Use) Regulations" (Statutory Instrument 1998 No. 2451).

- Check the gas supply to be sure that it is the same as the gas indicated on the heater's rating plate.
- If there is any doubt regarding the capacity of any existing service pipes or the size required for new service pipes then the advice of the gas supplier should be requested. Installation pipework should be fitted and tested for gas soundness. Zodiac recommends the gas inlet pipe sizes listed in Table 5.
- Use the figures in Table 5 to size the gas inlet piping from the gas meter to the heater. Check all local codes for compliance before installing the heater.

Table 5. Pipe Size Requirements*

Heater Size	Distance from Gas Meter		
	0-15 m mm	15-30 m mm	30-60 m mm
125	20	25	25
175	25	25	32
250	25	32	32
325	32	32	40
400	32	40	40

- Before operating the heater, test for gas soundness. Do not use a naked flame.
- If the gas supply pressure is less than required, check for undersized pipe between the meter and the heater, a restrictive fitting, or an undersized gas meter. Gas supply pressures to the heater are listed in Table 2.

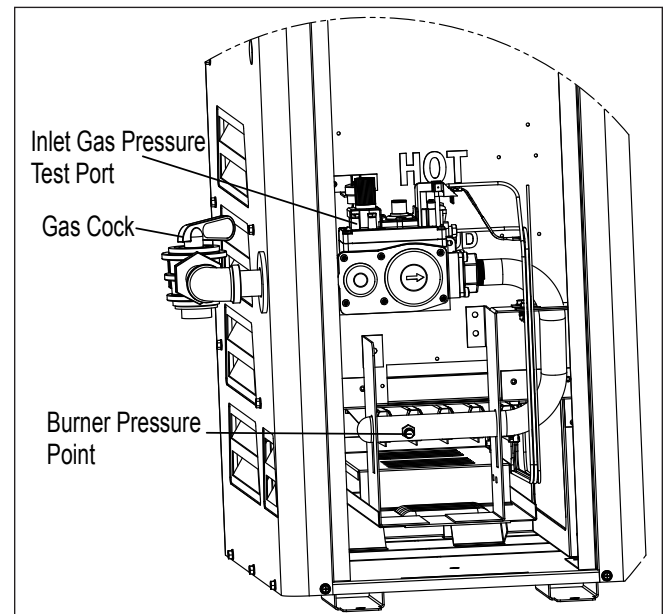

Figure 5. Fitting a Gas Service Cock

4.2 Burner Pressure

Confirm that gas supply pressure is correct. If the gas supply pressure is less than required, check for undersized pipe between the meter and the heater, a restrictive fitting, or an undersized gas meter. Gas inlet pressures to the heater, when it is operating, are listed in Table 2.

⚠ CAUTION

Burner gas pressure for the Legacy Model LRZ natural gas heaters should be set to the values listed in Table 2.

The burner pressure may be checked by connecting a manometer to the pressure port on the burner. Refer to Figure 5. The pressure will be zero when the heater is not running. When the heater is operating the burner gas pressure should be the values listed in Table 2.

If the burner pressure indicated above is not correct, check the gas train for possible problems. Check the meter, gas line, gas fittings, and gas shut off for under sizing. Check the gas valve inlet for excess pipe dope, if all is correct, then it may be necessary to adjust the gas valve regulator. To adjust the burner gas pressure, first remove the slotted cap next to the inlet pressure port on the inlet side of the gas valve. Under the slotted cap is a slotted plastic screw which increases the burner pressure when turned clockwise and decreases the burner pressure when turned counter-clockwise. After measurements, and adjustments if necessary, have been made, make sure to replace the test point plugs on the inlet and burner pressure ports, and the cap on the burner pressure adjustment screw. It is extremely important to replace these parts before leaving the installation. Failure to do so can result in damage to property or injury or death. *With the heater firing*, the pressure must be within the range shown in Table 2. Also check the pressure with the heater off.

4.3 Special Precautions for LPG

LPG is heavier than air and can therefore more readily collect or “pool” in enclosed areas if provision for proper ventilation is not made. Installation of pool heaters in enclosed areas such as pits is not recommended.

Consult any local code and fire protection authorities about specific installation restrictions in your area.

Section 5. Water Connections

5.1 Water Piping

Figure 6 illustrates typical piping for pool equipment in pool/spa combination pools.

For normal installations, do not install a shutoff valve or any kind of variable restriction in the water piping between the heater outlet and the pool/spa. In special installations where a shut-off valve, diverter valve or other variable restriction is required in the plumbing between the heater outlet and the pool, Zodiac recommends the installation of a pressure relief valve on the heater (see Section 5.7).

Arrangement of pool system components other than as illustrated in these diagrams can affect the operation of the heater’s water pressure switch. Location of the heater above or below the pool water surface can also affect operation of the switch. In general, the pressure switch can be adjusted to accommodate this effect if the heater water connections are no more than 1.8 m below the pool water surface and no more than 4.5 m above it. See instructions for pressure switch adjustment (Section 5.7) in the heater start-up section of this manual for more information about this.

Note that when pool equipment is located below the pool surface a leak can result in large scale water loss or flooding. Zodiac cannot be responsible for such water loss or flooding or the damage caused by either occurrence.

For special installations such as water connections below the water level of the pool, or for other questions consult your local Zodiac dealer.

5.2 Hydraulic Head Loss

To verify that the minimum flows required for the heater are met, a hydraulic head loss curve is shown in Figure 7. This should be checked when installing this heater into a new or existing piping system. This should also be consulted when installing a new pump.

5.3 Check Valve Installation

⚠ WARNING

A check valve can interfere with the proper operation of certain Suction Vacuum Release System (SVRS) products. To avoid possible entrapment hazard, serious injury, or death, make sure to review the operation/owners manual of your particular SVRS product before installing the check valve.

The heater must be protected from back-siphoning of water, which can result in dry starts. If there is any chance of back-siphoning, provide a check valve between the pool and the filter pump inlet.

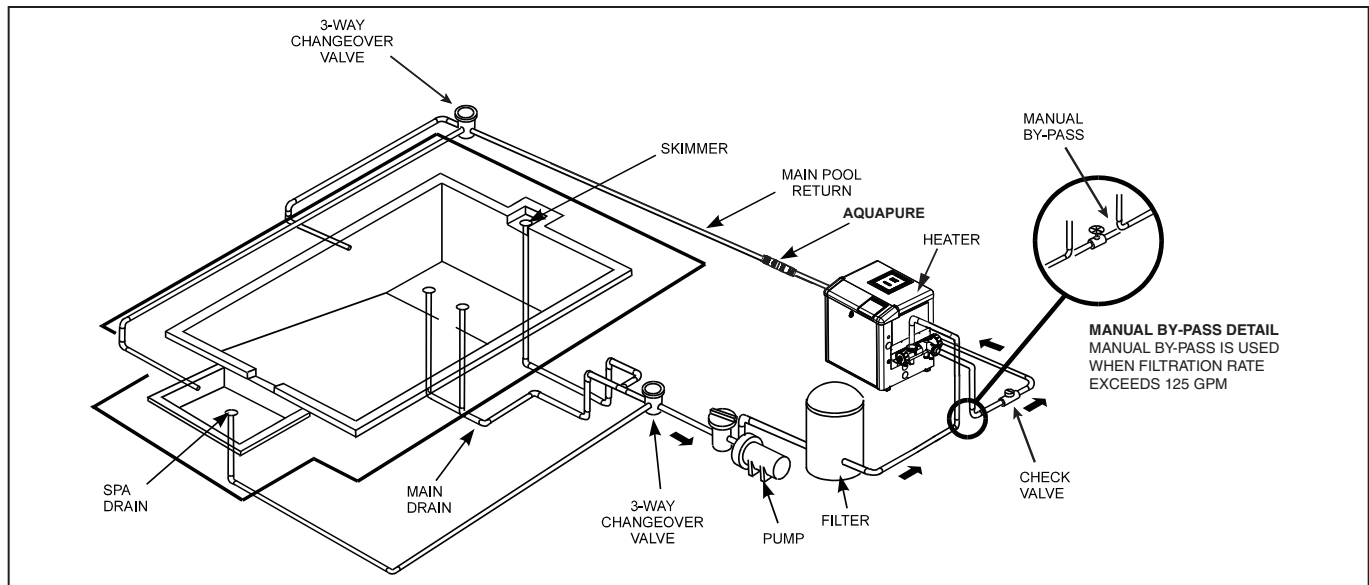

Figure 6. Typical Piping Installation

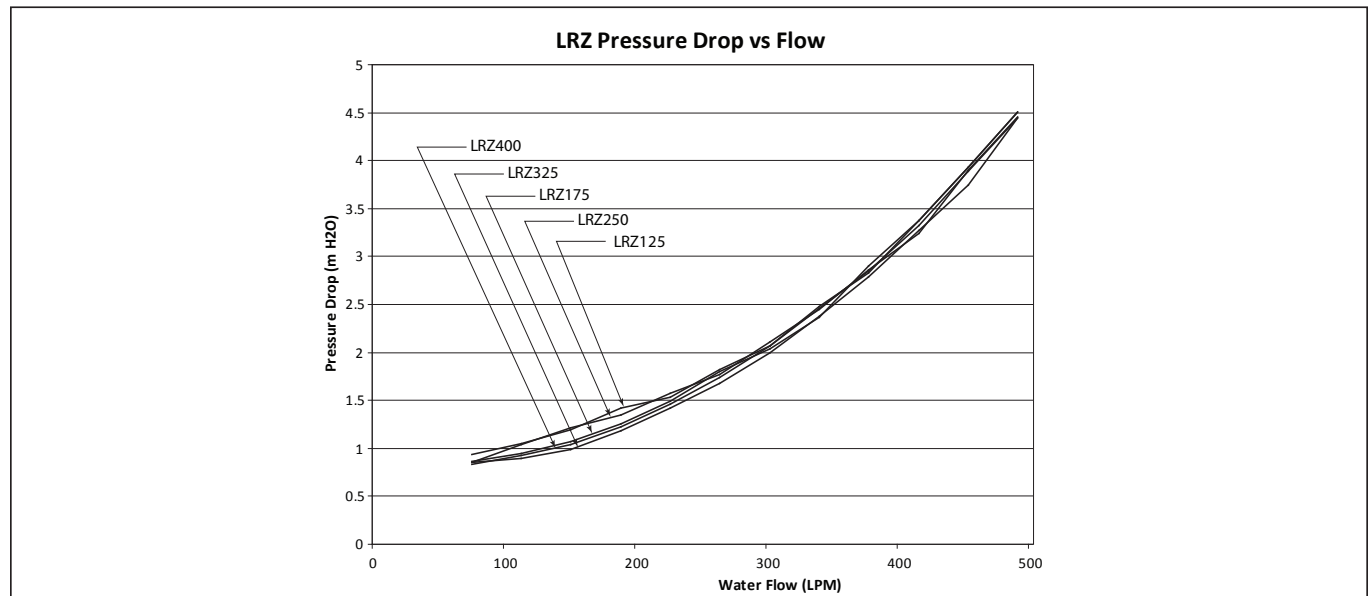

Figure 7. Hydraulic Head Loss Curve

When an automatic chemical feeder is installed in the plumbing, it must be installed downstream of the heater (see Section 5.7). A check valve must be installed between the heater and the chemical feeder to prevent back-siphoning of chemically saturated water into the heater where it will damage the components.

5.4 Automatic Flow Control Valve

The inlet/outlet header of the Legacy Model LRZ millivolt heater comes equipped with an automatic flow control valve. The automatic flow control valve maintains the proper flow through the heater at rates up to approximately 475 lpm. If the filter system flow rate is higher than approximately 475 lpm, install a manual bypass valve (see Figure 6), then perform a temperature rise test (see Section 11.6) and adjust the flow using the bypass valve until the proper temperature rise is obtained.

5.5 Reversible Water Connections

The Legacy Model LRZ millivolt heater is shipped with water connections on the right side, but can be modified in the field to provide left-side water connections. This procedure involves removing the heat exchanger headers and reinstalling them on opposite ends of the tube assembly. Some of the heater wiring must be disconnected and re-routed, so this procedure must be done only by a trained service technician. Heat exchanger reversals are generally done before the installation of power and water to the heater. If you need to reverse the heat exchanger on a previously installed heater be sure that all electrical power, the gas supply and water supply have been turned off before starting the procedure. These instructions have been written to include the steps needed when reversing the water connections on an existing installation. If you are reversing the headers on a new installation, some steps will be ignored.

Water connection reversal is illustrated in Figures 8 and 9. Proceed as follows:

1. For an existing installation, drain the heater by removing the two (2) drain plugs on the inlet/outlet header and the drain plug on the return header.
2. Remove the heater front panel (door).
3. Remove the I/O header side cover plates, top and bottom. See Figure 10.
4. Remove the return header side cover plates, top and bottom. See Figure 10.
5. Tag and disconnect the black high limit wire leading to the pressure switch (PS) and the black wire on the Fireman's switch terminal which leads to the high limit switch.
6. Remove the water temperature sensor nut from the inlet/outlet header and remove the sensor.
7. Tag and disconnect the black and white wires from the water pressure switch.

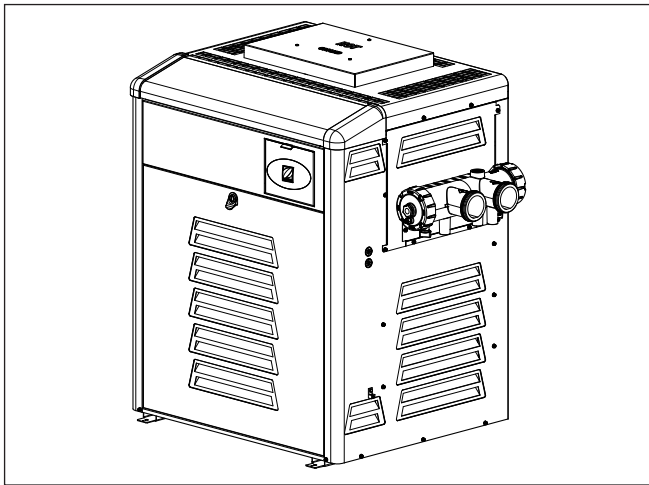

Figure 8. Water Connections as Shipped

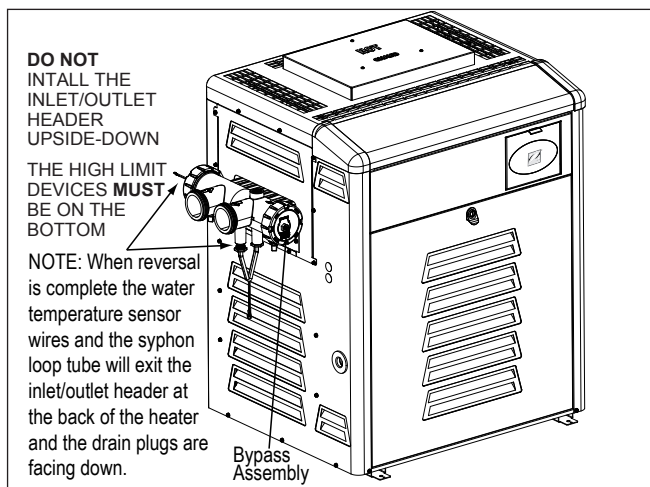

Figure 9. Water Connections Reversed

⚠ CAUTION

In order to prevent property damage or injury, ensure that the wiring is handled and routed carefully so as not to cause any damage to it. Additionally, be careful not to create any kinks in the water pressure switch copper tubing when handling the header.

8. For an existing installation, remove the coupling nuts from the header and disconnect the water supply from the heater.
9. Remove the 10 bolts and washers from the inlet/outlet header and remove the header from the tube assembly.
10. Remove the 10 bolts and washers from the return header and remove the header from the tube assembly.
11. For an existing installation, remove the tube gaskets and clean the header's mating surface of any corrosion or debris. Replace the tube gaskets with new ones. Do not use any metal tools on the header surface. Scratches may compromise the seal integrity.

⚠ WARNING

To avoid product failure which can cause property damage, serious personal injury or death, install the inlet/outlet header with the high limit devices on the bottom.

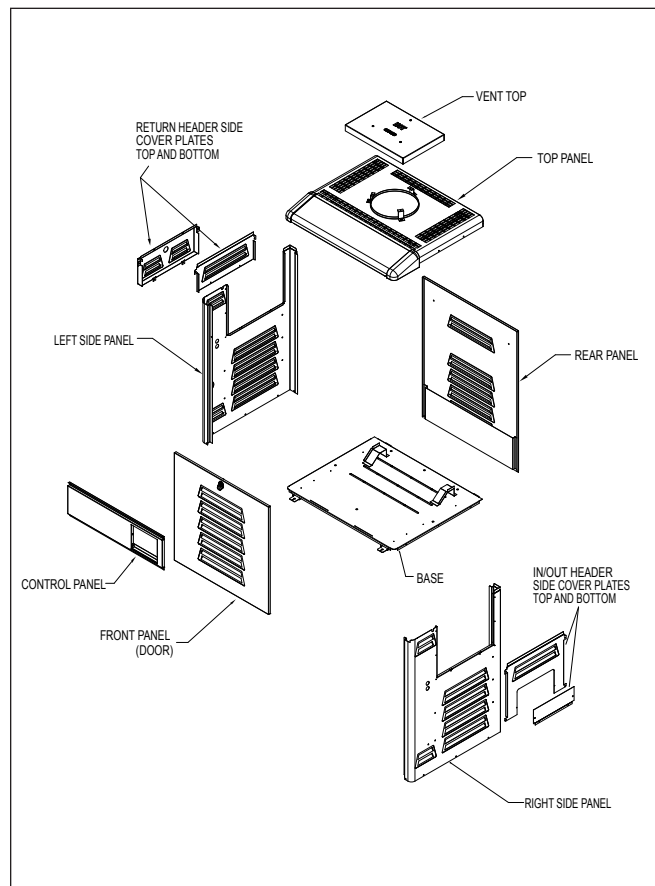

Figure 10. Legacy Panel Identification

12. Place the inlet/outlet header over the bolts and gasketed tubes on the left side of the tube assembly. Make sure the high limit devices are on the bottom. Refer to Figure 9. Align the bolt and tube holes in the header with the bolts and tubes in the header bar and slide the assembly together.
13. Thread on the 10 bolts and washers and hand tighten.
14. Place the return header over the bolts and gasketed tubes on the right side of the tube assembly. Align the bolt and tube holes in the header with the bolts and tubes in the header bar and slide the assembly together.
15. Thread on the 10 bolts and washers and hand tighten.
16. Use a torque wrench to tighten the bolts on each header to 4 ft-lbs. The bolts must be tightened in the sequence indicated in Figure 11.

⚠ CAUTION

Failure to tighten the header as indicated in step 16 may cause the header to leak or become permanently damaged from warping.

17. Remove the 3/4 inch button plug located in the left side panel below the inlet/outlet header and replace with the 3/4 inch wire grommet from the right side panel below the return header. The high limit leads were routed through this grommet prior to removal in step 5. Install the 3/4 inch plug in the opening where the 3/4 inch wire grommet was removed.
18. Reconnect the white wire on the pressure switch (PS) and the white wire on the Fireman's switch terminal.
19. Reinstall the temperature sensor in the inlet/outlet header and tighten the nut.
20. Reconnect the black and white wires to the water pressure switch.

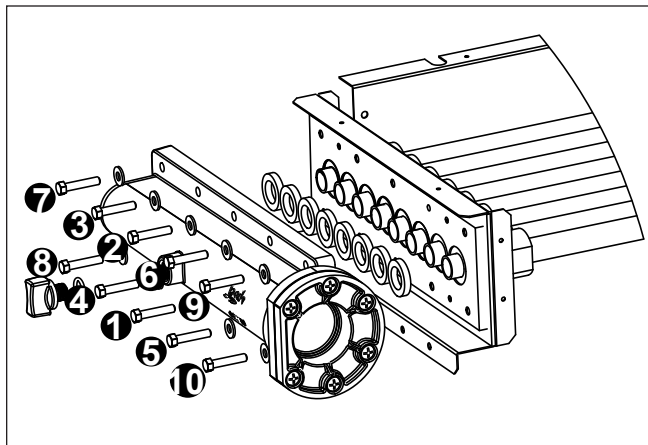

Figure 11. Header Bolt Tightening Sequence

21. Use plastic wire ties to refasten the temperature sensor, high limit switch and water pressure switch wires to each other. Bundle the wires near the control panel and fasten them with a wire tie.

⚠ CAUTION

In order to prevent property damage or injury, be sure that none of the wires are in contact with a sharp edge or a hot surface.

22. Install the return header side cover plate on the right side of the unit.
23. Install the I/O header side cover plates, top and bottom on the left side of the unit.
24. Replace the front panel (door).

5.6 Connections at Heater

The Legacy Model LRZ millivolt heater has a standard 2 inch water header and coupling design. With this feature, only nominal 2 inch PVC or CPVC may be connected to the heater. However, by installing the appropriate pipe adapters and two (2) short pieces of 2 inch plastic pipe (supplied by the installer), any size existing pipe may be fitted to the heater.

To connect a section of 2 inch PVC or CPVC pipe to the heater, first slip a coupling nut onto the pipe. Then prepare the end of the pipe with the proper PVC/CPVC primer and glue. Follow the manufacturer's instructions provided with the primer and glue for preparation procedures and curing times. Apply the slip-fit side of the coupling to the end of the pipe. Allow the glue to cure completely. Set the o-ring into the groove on the face of the coupling. Slide the coupling nut up to the coupling and tighten it to the threaded connection on the header (see Figure 12).

5.7 Pressure Relief Valve

A pressure relief valve (PRV) is recommended in all installations, and is mandatory in any installation in which the water flow can be shut off between the heater outlet and the pool/spa.

A pressure relief valve is not supplied with the Legacy Model LRZ millivolt heater. However, it is recommended that a pressure relief valve be installed and may even be required by local codes.

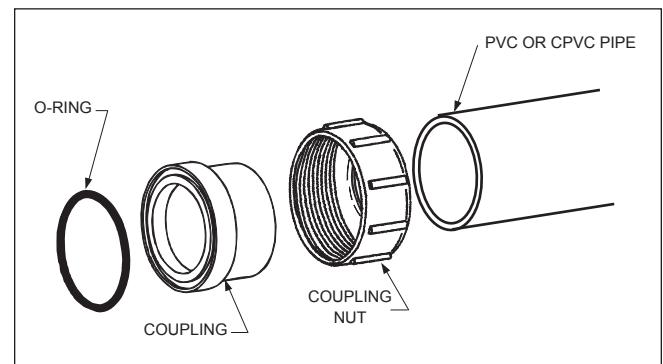

Figure 12. Piping to Heater

Be sure to check any applicable installation codes in your area to determine whether a pressure relief valve is required. See Section 12.2 (Parts List) of this manual for the appropriate kit part number.

The pressure rating of the valve should be at or below the lowest working pressure of any component in the system. The maximum working pressure of this heater is 5.1 bar.

Follow these steps to install a pressure relief valve:

1. To protect the threads while drilling, screw the brass adapter (included with the Zodiac PRV kit) into the blind threaded hole on the top of the inlet/outlet header.
2. Using the countersink in the center of the blind hole as a guide, drill a 6.4 mm (1/4 inch) hole through the plastic (see Figure 13).
3. Open the hole by reaming it with a 9.5 mm (3/8 inch) drill bit.
4. Open the hole again by reaming it with a 12.7 mm (1/2 inch) drill bit.

⚠ CAUTION

Initially drilling a 12.7 mm (1/2 inch) hole without reaming may cause the bit to "grab" on the plastic. This may cause personal injury or damage the plastic header.

5. Remove the brass adapter and clean the cuttings out of the hole.
6. Install the rubber washer at the bottom of the hole (see Figure 14).
7. Thread the adapter into the hole and tighten so that it seals against the rubber washer.
8. With a permanent marker, place a mark on the adapter so that the mark faces the same direction as the water connections on the header.
9. Remove the adapter from the hole.
10. Coat the threads of the pressure relief valve (PRV) with an appropriate metal to metal thread sealant.
11. Install the adapter on the PRV and tighten using two (2) wrenches. Use the mark made earlier on the adapter to orient the PRV to the desired direction in relation to the water connections on the header.
12. Reinstall the adapter, with the PRV, into the plastic threaded hole and tighten it until the mark on the adapter is once again facing the same direction as the water connections on the header.

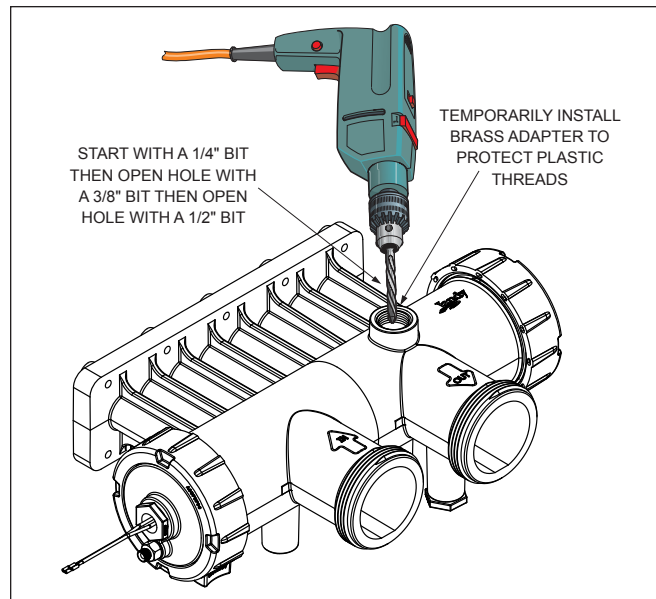

Figure 13. Drill Hole for Pressure Relief Valve

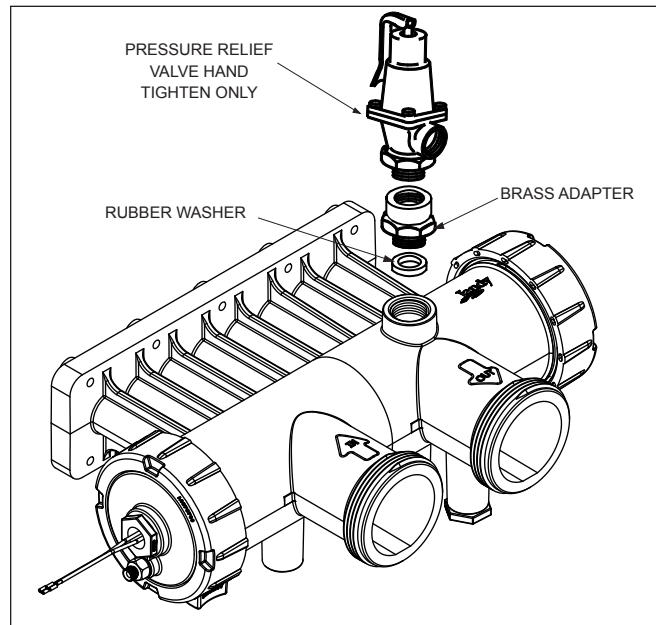

Figure 14. Pressure Relief Valve Installation

⚠ CAUTION

Do not use any pipe compound or pipe dope on the threads of the adapter or any part that comes in contact with the plastic headers. These compounds may damage the header over a period of time.

⚠ CAUTION

In order to prevent property damage, do not over-tighten. Overtightening may crack the header.

DO NOT TIGHTEN WITH A WRENCH.

Overtightening may crack the header. Route the discharge piping so that discharge from the pipe does not endanger anyone near the heater.

Refer to your local installation codes for more detailed information. The valve setting should be at or below the maximum working pressure of any component in the filter system. The maximum working pressure of the Legacy Model LRZ millivolt heater is 5.1 bar.

5.8 Auxiliary Components, Chlorinators, Ozone Generators, and Sanitizing Chemicals

The Legacy Model LRZ millivolt heater is manufactured with materials that are not compatible with high concentrations of ozone, chlorine, bromine, or other sanitizing chemicals. Heater damage caused by excessive chemicals or improper ozonization is not covered by the Zodiac warranty. Be sure to adhere to the following:

- When ozone is injected upstream of the heater, install an offgas mixing chamber, or an ozone bypass system between the heater and the ozone injector to prevent ozone and air from entering the heater.
- When chemical feeders are used, plumb the feeder downstream of the heater and install an in-line check valve between the heater and the feeder (a minimum of 450 mm is required between the heater and the check valve).
- Wire any electrical chemical feeder so that it cannot operate unless the filter pump is running. If the feeder has an independent clock control, synchronize it with the filter clock.
- Never deposit chemicals directly in the pool skimmer.

Section 6. Electrical

WARNING

This product must be installed and serviced by a contractor who is licensed and qualified in pool equipment by the jurisdiction in which the product will be installed where such state or local requirements exist. In the event no such state or local requirement exists, the installer or maintainer must be a professional with sufficient experience in pool equipment installation and maintenance so that all of the instructions in this manual can be followed exactly. Before installing this product, read and follow all warning notices and instructions that accompany this product. Failure to follow warning notices and instructions may result in property damage, personal injury, or death.

CAUTION

Label all wires prior to disconnection when servicing controls. Wiring errors can cause improper and dangerous operation. Verify proper operation after servicing.

6.1 Main Power

The Legacy heater does not require an external source of electrical power to operate. The power for the gas valve and safety circuit are generated by a thermopile. The thermopile generates a millivolt signal when heated by the pilot flame. Figure 15 shows the internal electrical wiring diagram and schematic of the heater.

6.2 Earth Bonding

CAUTION

To prevent premature failure of the appliance resulting from stray voltages and voltage differentials, the heater must be bonded to other equipment which is part of the pool plumbing system with a solid copper wire not smaller in diameter than 8 AWG (10mm²).

Zodiac requires that the appliance be connected to an "earth bonding loop" that includes all electrical equipment in the system and on the equipment pad. Earth bonding lugs must be connected with a solid copper wire not smaller than 8 AWG (10mm²). Failure to do so will void warranty.

Additionally, all metallic components of a pool structure, including reinforcing steel, metal fittings and above ground components be bonded together (forming an "earth bonding grid") with a solid copper conductor not smaller than a 8 AWG (10mm²).

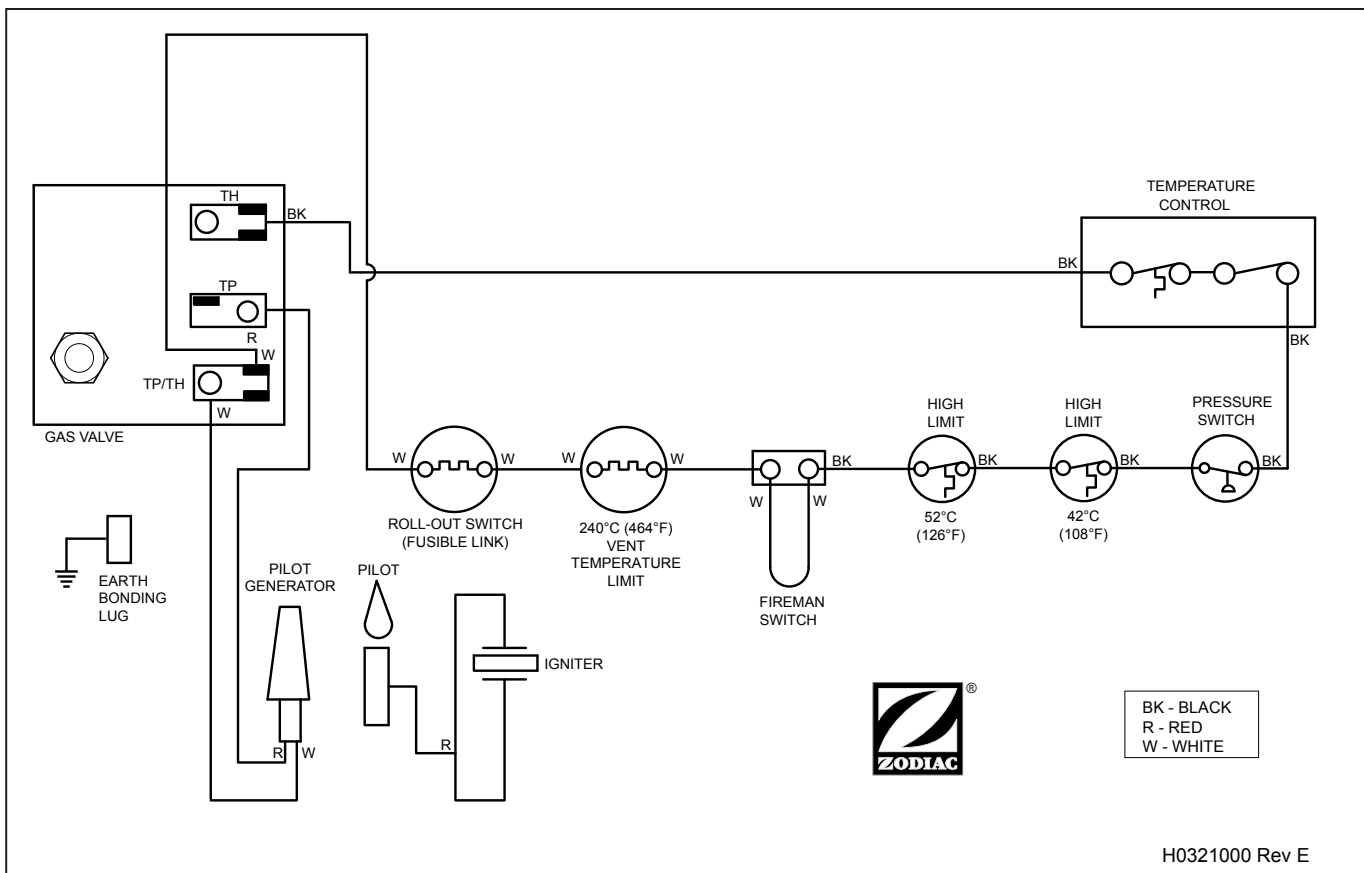

Figure 15. Legacy Wiring Diagram

The equipment and/or appliances associated with the pool water circulating system, including, but not limited to, pump motors and heaters must also be bonded together as part of the equipotential bonding grid. Zodiac provides a special labeled earth bonding lug on the right side of the heater to accommodate this requirement. Consult your local applicable installation codes/regulations for additional requirements that may apply.

6.3 Auxiliary Time Clock Wiring

If you install a time clock to control the filter pump operation, it is recommended that the time clock have its own low voltage (Fireman's) switch to turn off the heater before turning off the pump. The switch should shut off the heater about 15 minutes before the filter pump shuts off. This will allow for a more efficient operation by removing any residual heat contained in the heat exchanger back to the pool.

To install a time clock auxiliary switch into the heater wires (see Figure 16):

1. Remove heater door.
2. Remove the factory installed wire between terminals 1 and 2 on the terminal strip (see Figure 16).

3. Connect the wires from the time clock auxiliary switch to the two (2) terminals. Use 14 AWG (2,5 mm²) stranded copper wire with a temperature rating of 105°C (221°F) or greater.

The length of the wire between the heater and the time clock should not exceed 4.57 m. The contact points of the time clock switch should be silver, or a low resistance alloy.

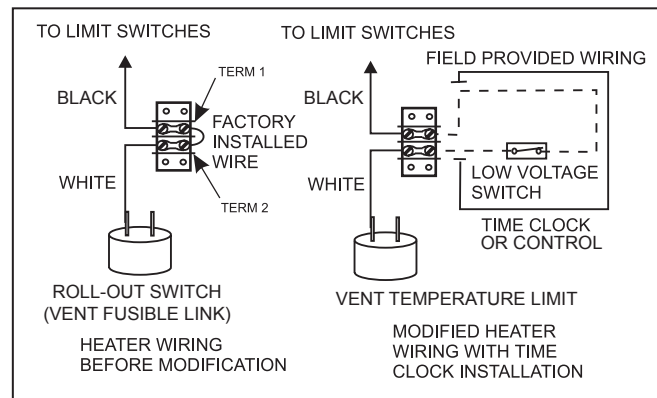

Figure 16. Time Clock Wiring or Control Connection

Section 7. Commissioning

7.1 Heater Start-Up

1. When the heater has lit, remove the service door and check all gas connections for soundness with leak detection fluid.
2. Check the manifold (burner) pressure setting and adjust as necessary (see Table 1).
3. Start the adjustment procedure with the heater cold, on full load, and with the temperature control set at maximum. This will ensure, as far as possible, that thermostatic shutdown does not interfere while the pressure is being checked and adjusted.
4. Remove the blanking screw in the manifold (burner) setting pressure test nipple (see Figure 17) and securely connect a suitable gas pressure gauge.
5. Light the heater and allow it to operate for about 15 minutes to stabilize the burners.
6. Check the pressure and adjust it for the appropriate heater size. Refer to Table 2. The burner pressure setting adjuster is found on the gas control (valve).
7. Remove the dust cover over the adjuster and, using a screwdriver, turn the screw beneath clockwise to increase or anti-clockwise to decrease the pressure. Replace the dust cover when finished.
8. Turn off the burner, disconnect the gas pressure gauge, and replace the blanking screw in the burner setting pressure test nipple.
9. Relight and check for gas soundness.
10. For heaters installed with a draft hood, perform a spillage test in accordance with BS.5440:1 to check for spillage of combustion products from the heater draft diverter.
11. Check that the main burner responds correctly to manual ON/OFF operations of any controls fitted in the gas control circuit.
12. Check the operation of the flame failure safety device using the following steps:
 - a. Extinguish the main burner and pilot burner by turning off the main gas inlet cock.
 - b. Check that the flame failure device is heard to close within one (1) minute.
 - c. Wait three (3) minutes, then turn on the gas and re-light the pilot.
13. With the pump running, check for water leaks in the heat exchanger or water piping.
14. Adjust the water pressure switch according to the procedure in Section 11.5.
15. Perform a temperature rise test according to the procedure in Section 11.6.
16. Refit the service door and return all controls to the required settings.

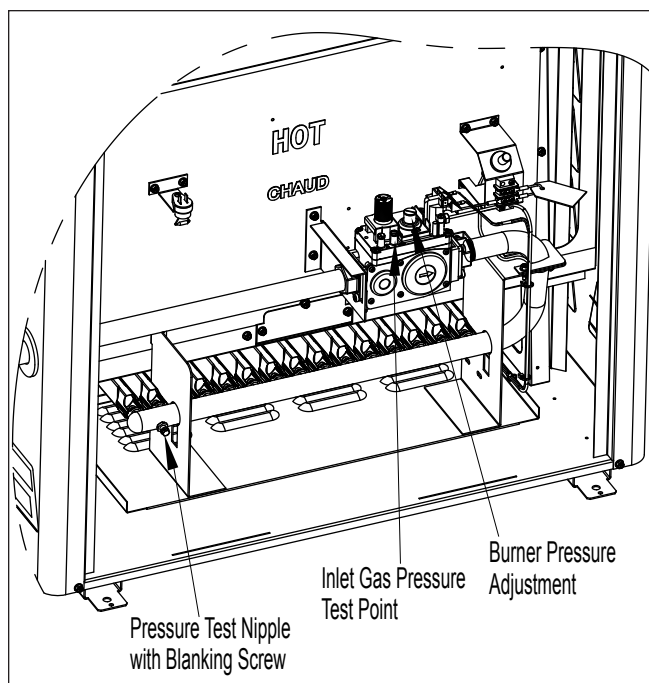

Figure 17. Lighting the Pilot

Section 8. Operating Instructions

8.1 Normal Operation

⚠ WARNING

Improper installation or maintenance can cause nausea or asphyxiation from carbon monoxide in flue gases which could result in severe injury, or death. For indoor installations, as an additional measure of safety, Zodiac strongly recommends installation of suitable Carbon Monoxide detectors in the vicinity of this appliance and in any adjacent occupied spaces.

The Legacy model LRZ millivolt heaters are capable of automatic operation based on a call for heat at a preset temperature. The heater has an internal safety system which allows operation in a variety of conditions and prevents operation when certain adverse conditions are encountered.

When the heater's pilot is lit and the pilot generator is providing a millivolt signal to the safety circuit, water is flowing through the heater, and the temperature of the water entering the heater is below

the temperature control setting, an operating cycle is initiated by the automatic control. The temperature control circuit is closed, activating the gas valve and the gas valve is opened. Gas flows through the burners, is mixed with air in the combustion chamber, and is ignited by the pilot. Operation will continue until the temperature of the water entering the heater reaches the temperature control setting.

If ignition is unsuccessful, or if the flame fails during normal operation, the temperature control circuit opens and shuts off the gas valve.

8.2 Start-Up

CAUTION

Do not use this heater if any part has been under water. Immediately call a qualified service technician to inspect the heater and replace any part of the control system and any gas control which has been under water.

CAUTION

Should overheating occur or the gas supply fail to shut off, turn off the manual gas control valve to the heater.

CAUTION

Do not attempt repairs on the gas controls or appliance. Tampering is dangerous and voids all warranties.

CAUTION

Keep all objects off the top of the heater. Blocking air flow could damage the heater, and may void the warranty.

WARNING

Vent pipes, draft hoods, and heater tops get hot! These surfaces can cause serious burns. Do not touch these surfaces while the heater is in operation. Adding a vent cap reduces the temperature on the top.

WARNING

For your safety, when starting the heater, keep your head and face well away from the lower firebox opening to prevent any risk of personal injury.

Be sure that there is water in the pool and that the surface level is above the skimmer or other inlet of the pool's filter system.

Confirm that pool water is flowing normally through the pool system and equipment. With any new pool or spa installation, operate the filter pump with the heater off long enough to completely clean the water. This will remove any installation residue from the water. Clean the filter at the end of this operation before starting the heater. Start the heater in accordance with the Operating Instructions section of this manual, with particular attention to the lighting and shutdown instructions and temperature control operation.

The heater may not start on the first try. Air in the gas line or other start-up situations may cause it to cycle.

When raising the temperature of a cold pool, remove all time clock settings. This lets the filter system and heater operate continuously until the water reaches the temperature setting on the temperature control. When that happens, the heater will automatically shut off, but the filter pump will keep running.

When the heater starts, immediately feel the outlet header of the heater to confirm that there is adequate water flow. The header should not be hot. Normally, water temperature will rise only a few degrees as it passes through the heater, and a "hot" header or pipe indicates low water flow.

WARNING

When the heater is fired for the first time, the combustion chamber refractory binder material is driven out by the heat of the flame. White smoke and/or sharp odors may be emitted from the vent during this period. Do not inhale combustion product fumes at any time, and especially when these fumes are being emitted. This "burn-in" period will last only a few minutes.

8.3 Lighting and Shutdown Procedures

Before starting your heater, be sure that you are familiar with the setting and operation of the heater controls. Once the controls are set to your preferences, follow the instructions outlined on the following page. **Read and follow all safety instructions first.**

A more detailed set of instructions of the operation of the controller follows in the next section.

NOTE If your heater is configured to operate on LPG and the LPG tank runs out of fuel, turn off gas at the heater. After the tank is refilled, the heater must be relit following the instructions found on the inside of the heater. A copy of these instructions appears on the following page.

WARNING

DO NOT attempt repairs on the gas control or heater. Tampering can cause severe bodily injury or death and voids all warranties.

WARNING

Do not attempt to operate the heater with the door off. Doing so may cause severe bodily injury.

8.3.1 Lighting the Heater

Full lighting and shutdown instructions can also be found attached to the wall inside the control compartment door. See Figure 18.

1. Remove the service door on the front of the heater.

⚠ WARNING

LP Gas Models: To avoid possible injury, fire and explosion, read and follow these precautions and all instructions on this appliance before starting the heater. LP (propane) gas is heavier than air and will remain at ground level if there is a leak. Before lighting, sniff at ground level. If you smell gas, follow these rules:

1. DO NOT light matches. DO NOT turn electric lights or switches on or off in area. DO NOT use an electric fan to remove the gas from area.
2. Shut off gas at LP tank.
3. Telephone gas company and fire department for instructions. Give your name, address and phone number.

If your LP tank runs out of fuel, turn off gas at the appliance. After the tank is refilled, the appliance must be re-started according to the instructions located on the inside of the door.

⚠ WARNING

Natural Gas Models: To avoid possible injury, fire and explosion, read and follow these precautions and all instructions on this heater before lighting the pilot. If you smell gas, follow these rules:



1. DO NOT light matches. DO NOT turn electric lights or switches on or off in area. DO NOT use an electric fan to remove the gas from area.
2. Shut off gas at gas service cock.
3. Telephone gas company and fire department for instructions. Give your name, address and phone number.

DO NOT attempt repairs on the gas control or heater. Tampering is dangerous and voids all warranties.

FOR YOUR SAFETY READ BEFORE OPERATING

⚠WARNING: If you do not follow these instructions exactly, a fire or explosion may result, causing property damage, personal injury or loss of life.



LIGHTING INSTRUCTIONS**INSTRUCTIONS TO LIGHT HEATER**

1. Position ON/OFF switch to "OFF".
2. Turn gas control knob clockwise  until it stops at "●" (OFF) position.
3. Wait five (5) minutes before lighting pilot.
4. Turn knob on gas valve counterclockwise  to "★" (PILOT) then push control knob all the way and hold down. Push the button of the sparker, repeating until confirming that pilot lights, by observing reflection on burner tray mirror. Continue to hold the control knob in for about one (1) minute after the pilot is lit. If it goes out, repeat steps 3 and 4.
5. Turn gas control knob counterclockwise  to "🔥" (ON).
6. After replacing door, set thermostat to desired setting and turn appliance ON/OFF switch to "ON". Valve has built-in delay before coming on.

RELIGHTING

If pilot goes out, repeat steps 1 through 6.

TO SHUT OFF HEATER

To shut off main burners turn gas control knob clockwise  until it stops at "★" (PILOT). For complete shut-off press down slightly on knob while turning clockwise  to "●" (OFF). Do not force. Position ON/OFF switch to "OFF".

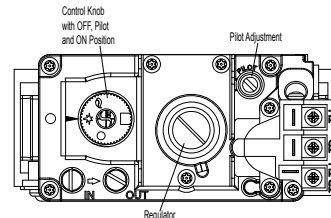
**IMPORTANT INFORMATION**

1. **CAUTION:** Do not store pool chemicals or flammable materials near this appliance.
 2. **PH LEVEL:** Pool Water must be maintained between 7.4 and 7.6 when operating unit (See section entitled "Water Chemistry" in operating manual).
 3. **BACKWASHING:** Turn heater off 20 minutes before backwashing or shutting down filter to prevent damage to unit.
 4. **WINTERIZE:** All gas to unit must be shut off and all water drained from unit to protect it from freezing damage.
- NOTE:** THIS DOOR MUST BE FITTED TO UNIT DURING NORMAL OPERATIONS.

FOR YOUR SAFETY

DO NOT STORE OR USE GASOLINE OR OTHER FLAMMABLE VAPORS OR LIQUIDS IN THE VICINITY OF THIS OR ANY OTHER APPLIANCE.

NOTE: SOME EXPOSED PARTS OF THIS HEATER MAY BE HOT WHEN OPERATING.



H0320600 Rev B

Figure 18. Legacy Lighting and Shutdown Procedures

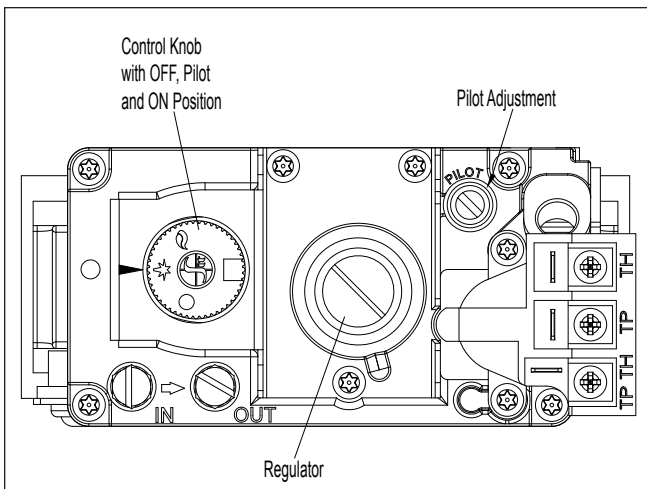

Figure 19. Natural Gas/Propane Control Valve

2. Turn the gas control knob clockwise until it stops at the OFF position (see Figure 19).
3. Wait five (5) minutes before lighting the pilot.
4. Turn the knob on the gas valve counterclockwise to PILOT, then push the control knob all the way and hold down. Push the button of the sparker, repeating until confirming that the pilot lights by observing the reflection on the burner tray mirror. Continue to hold the control knob in for about one (1) minute after the pilot is lit. If it goes out, repeat Steps 3 and 4.
5. Release the control knob and verify that the pilot is lit.
6. If the pilot burner does not remain lit when the button is released, press and release the red button. Wait at least three (3) minutes and then repeat the lighting procedure from step 4.
7. If the pilot cannot be established, check that the pilot burner flame correctly envelops the thermocouple tip by 10 to 13 mm. If not, check that the pilot adjustment screw on the gas control (see Figure 19) is fully unscrewed, then turn it one (1) turn back in. Check that the thermocouple lead connections at the gas control and at the overheat thermostat are clean and secure. Repeat from Step 4.
8. Turn gas valve knob to ON. Replace the service door.
9. Turn the rocker switch to ON.
10. Set temperature control to against the Temp-Lok tab. The main burner should light. Until the water reaches a temperature of about 21°C (70°F), it is normal to have some water accumulating in the base of the heater.
11. Set the time clock, if one is installed.

8.3.2 Relighting the Heater

If the pilot goes out, repeat steps 5 through 7 in Section 8.3.1.

8.3.3 Shut-Down Procedure

1. To turn the main burner off, turn the rocker switch to OFF.
2. To turn the heater off (including the pilot), turn the gas valve knob to the OFF position.

8.4 Turning the Heater On/Off and Setting the Temperature Control

The temperature control (see Figure 20) is calibrated at the factory and covers a range from approximately 21°C to 40°C (70°F to 104°F). Use an accurate pool thermometer to determine the best water temperature for your use.

The Legacy temperature control panel has a rocker switch to turn the heater on and off. It also has a rotary dial to set the desired thermostat setting (see Figure 20).

Once the heater has been lit by following the safety and lighting procedures in Section 8.3, set the toggle switch on the control panel to "ON" to start the heater operation. If the heater senses that the pump is on and the thermostat setting is higher than the temperature of the pool/spa water, the pilot will ignite the main burners.

⚠ CAUTION

In order to prevent property damage, the heater is designed to run only when the filter pump is running. If the heater does not immediately turn off when the pump turns off, turn the heater off at the control panel. The heater's pressure switch may need adjusting (see Section 11.5)

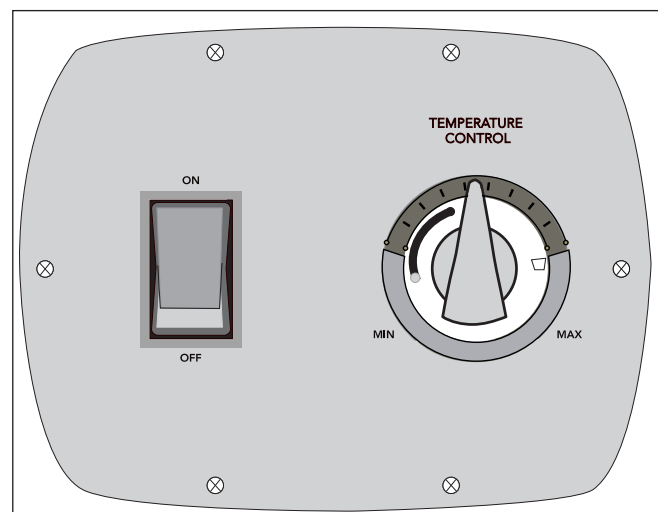

Figure 20. Temperature Control

Once the pool/spa water temperature reaches the thermostat setting, the heater will automatically stop firing. As the pool/spa water temperature falls below the thermostat setting the heater will once again start the heating cycle.

Rotate the thermostat dial clockwise to increase the temperature setting and counterclockwise to decrease the setting. It may take several attempts to set the thermostat dial to the desired temperature. Be sure to use an accurate thermometer to measure water temperature. Once the desired temperature setting is found, loosen the screw on the Temp-Lok ring and rotate the ring until the stop rests against the knob. Tighten the screw to hold the knob in position. This will prevent accidental moving of the dial and possible overheating of the water.

IMPORTANT: The temperature controls cannot be calibrated in the field. If the control is faulty, shut down the heater by following the procedures in Section 8.3 and have a qualified service technician replace the control. **DO NOT** use the thermostat switch to completely shut down the heater.

Section 9. Maintenance

9.1 Water Chemistry

The mineral content of swimming pool water increases daily due to natural evaporation and the addition of sanitizing chemicals. If the mineral concentration in the pool gets too high, the excess minerals will deposit on the walls of the pool, in the filter system, and in the heater tubes.

The proper chemical balance in spa water is more critical than in a swimming pool heater operation. Due to the spa's size, high water temperature and heavy usage, chemical values in a spa can vary greatly. This chemical imbalance can result in unsanitary water conditions, and affect the life of the heater.

Proper chemical balances are necessary for sanitary bathing conditions as well as ensuring your heater's long life. Kits are available from your local pool supply dealer for making the various tests for mineral content. One of these kits will detect copper in the system. This is usually a warning that corrosion is taking place, possibly due to a low pH value combined with other chemistry problems. The condition can be corrected by changing the spa water and closely monitoring the pH factor and chemical properties of the water. Be sure to keep your chemical levels within the values indicated in Table 7. **Zodiac does not warrant heat exchangers damaged by corrosive chemical levels or excess dissolved solids in pool or spa water.**

For spas, it is also necessary to perform water changes in addition to chemical treatment. It is recommended to change the spa water every 60 days for light usage and every 30 days if usage is heavy.

Table 7. Optimal Water Chemistry Ranges*

Test	Recommended Level
Free Chlorine	1.0 to 3.0 ppm
Bromine	2.0 to 4.0 ppm
pH	7.4 to 7.6
Total Alkalinity (TA)	80 to 120 ppm
Calcium Hardness (CH)	175 to 400 ppm
Cyanuric Acid	10 to 50 ppm
Total Dissolved Solids (TDS)	1000 to 2000 ppm (Excluding dissolved NaCl from a Salt Chlorine Generator)
Copper	0 ppm

* Concentration levels taken from "Basic Pool and Spa Technology" published by APSP (Association of Pool and Spa Professionals).

9.2 Seasonal Care

CAUTION

Do not operate this heater outdoors at temperatures below 20 degrees Fahrenheit (°F) (-7 degrees Celsius [°C]).

9.2.1 Spring and Fall Operation

During periods when the pool is only going to be used occasionally, turn the temperature control down to the MIN setting. This prevents the pool water from becoming chilled, and minimizes the time required to raise the pool water back up to the desired temperature.

In areas subject to only short freeze periods, turn off the heater and run the pump continuously for the length of the freeze period.

If the heater is not going to be used for a long period of time, shut it down completely. Refer to Figure 19 and follow the instructions found on the inside of the heater:

9.2.2 Winterizing

In areas where freezing temperatures occur in winter, and the pool or spa will not be used, have your service technician perform the following steps:

1. Turn off the main gas supply valve to the heater, outside the heater jacket.
2. Remove heater door.
3. Shut down the heater following the shutdown instructions found on the inside of the heater or Figure 19.
4. Remove the drain plug from the inlet/outlet header, and completely drain the heater before the first frost. See Figure 21.

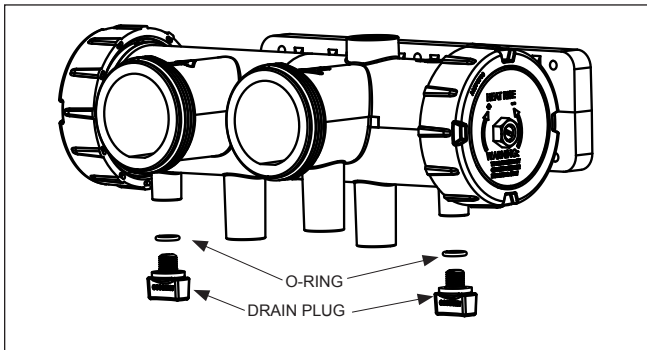

Figure 21. Draining the Heater

5. After all water has drained from the heater, check for mineral buildup in the openings.
6. Use compressed air to blow out any standing water remaining in the heat exchanger.
7. Inspect the gaskets on the drain plugs and reinstall the plugs, but do not tighten.
8. Disconnect the pressure switch from the copper tubing. See Figure 22.

9.2.3 Spring Start-up

To restart the heater in the spring, have a professional service technician reassemble the heater as follows:

1. Attach the copper tubing to the pressure switch (see Figure 22).
2. Tighten the drain plugs.
3. Turn on the filter pump and circulate water through the heater for five (5) minutes. Check for leaks while circulating.
4. Turn on the main gas supply valve to the heater, outside the heater jacket.
5. Turn on the heater following the lighting instructions found on the inside of the heater, or Figure 19 of this manual.

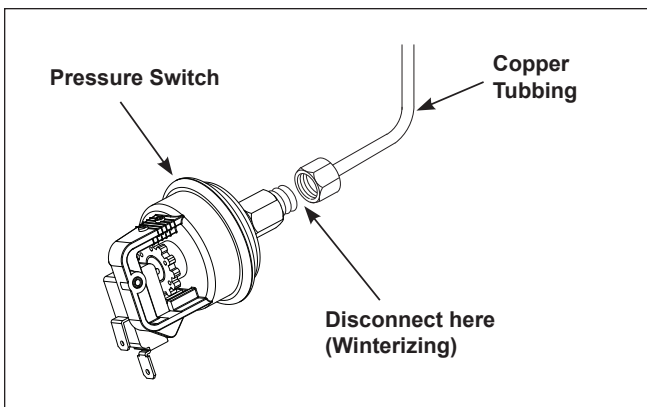

Figure 22. Pressure Switch Copper Tubing

9.3 Inspection and Service

The Legacy heater is designed and constructed to provide long performance life when installed and operated properly under normal conditions. Periodic inspections, especially at spring start-up, are important to keep your heater running safely and efficiently through the years.

⚠ WARNING

Improper installation or maintenance can cause nausea or asphyxiation from carbon monoxide in flue gases which could result in severe injury, or death.

9.3.1 Owner Inspection

Zodiac recommends that you inspect the heater on a continual basis and especially after abnormal weather conditions. The following basic guidelines are suggested for your inspection:

1. Keep the top and surrounding area of the heater clear of all debris.
2. Keep the area around and beneath the heater clean and free of all combustible materials such as paper, leaves, etc.

⚠ CAUTION

Do not store or use gasoline or other flammable vapors, liquids or chemicals in the vicinity of this or any other appliance.

⚠ WARNING

Do not use this heater if any part has been under water. Immediately call a qualified service technician to inspect the heater and replace any part of the control system and any gas control which has been under water.

3. If the heater is equipped with a pressure relief valve, check for corrosion in and around the valve. Twice a year, with the filter pump on, lift the release lever on the top of the valve to make sure that water runs freely through it. If corrosion is found, replace the pressure relief valve. When replacing the valve, be sure that the pump is off. Install the valve so that the discharge is directed away from any area that may be damaged by water.
4. Be sure all combustion air and ventilation openings are not blocked. Check for spider webs and other debris inside the heater, in the vents on all sides of the heater jacket and in the exhaust outlet—especially after a long period of nonuse.

9.3.2 Professional Inspection

Inspections performed at least once a year by a qualified technician are required to maintain your heater's safe and efficient operation. The following basic safety checks must be performed.

1. Inspect the venting system for blockage, leakage, and corrosion.
2. Inspect burners and verify that they are clean. Clean with a wire brush if necessary to remove debris.
3. Check for spider webs and other debris in the pilot and main burner orifices - especially at spring start-up.
4. Check for loose or broken wires and terminal connections.
5. Make sure that the pressure switch operates properly by shutting the filter pump off and on a few times. The burner should go off immediately after the pump stops. An ignition sequence should start shortly after the pump is turned back on.
6. Make a visual check of the main burner and pilot flame patterns. The flame can be seen in a mirror arrangement held beneath the burners. The flame should be:
 - a. Blue in color.
 - b. 25 mm to 102 mm above burner surface (see Figure 23).
7. Inspect the gas and electronic controls, including the following:
 - a. High temperature limit switch
 - b. Water pressure switch
 - c. Automatic gas valve
 - d. Roll-out switch (fusible link)
 - e. Temperature control
 - F. Vent temperature limit
8. Perform a temperature rise test in accordance with Section 11.6.
9. If the heater is equipped with a pressure relief valve, check for corrosion in and around the valve. With the filter pump on, lift the release lever on the top of the valve to make sure that water runs freely through it. If corrosion is found, replace the pressure relief valve. When replacing the valve, be sure that the pump is off. Install the valve so that the discharge is directed away from any area that may be damaged by water.

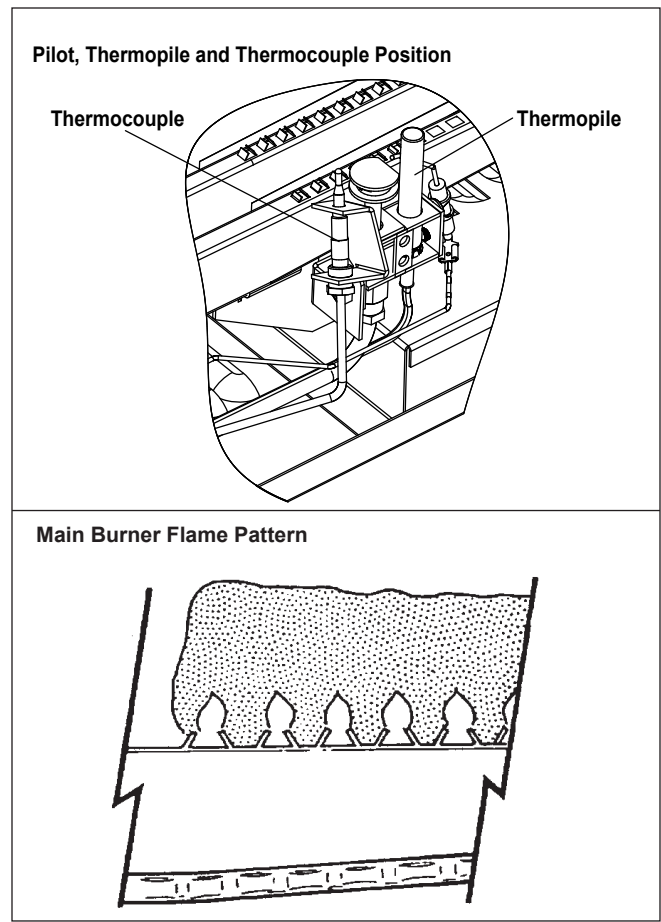

Figure 23. Pilot, Thermopile and Thermocouple Positions, and Main Burner Flame Patterns

10. Inspect the external surfaces of the heat exchanger tubes for black carbon soot buildup by placing a mirror between and under the burners when the heater is firing. Remove any soot that has collected on the tubes, and correct the cause.
- NOTE** After installation and first start-up, check the heat exchanger for black carbon soot buildup after the following periods of operation: 24 hours, 7 days, 30 days, 90 days, and once every 6 months thereafter.
11. Conduct a normal operating cycle and observe that the sequence proceeds as intended.

CAUTION

For your safety, when starting the heater, keep your head and face away from the burner area opening to prevent any risk of personal injury.

- NOTE** Keep this manual in a safe place for future reference by you and your professional technician when inspecting and servicing the heater.

Section 10. Troubleshooting

10.1 General Heater Troubleshooting

Table 8 lists some of the more common problems, causes and solutions encountered when running the heater. Most problems occur when the heater is being started for the first time after installation or at spring start-up. Careful installation and maintenance will help ensure years of trouble free use from your Legacy heater.

Table 8. Legacy Troubleshooting Guide

#	Symptom	Cause	Remedy
1.	Pump not operating	A. No power. B. Pump defective. C. Incorrectly wired.	A. Check circuit breakers and power source. B. Replace pump.* C. Recheck wiring.*
2.	Pilot outage	A. Inlet gas pressure too low. B. Inlet gas pressure too high causing an unstable blowing pilot. C. Weak or defective thermocouple or thermopile. D. Damaged pilot, thermocouple or thermopile. E. Dirty pilot. F. Plugged or undersized pilot orifice. G. Plugged burner orifice(s).	A. Consult gas utility company. Inlet gas pressure to heater should be 13.7 to 24.9 mbar on natural gas. 24.9 to 34.8 mbar on propane gas.* B. Pressure should be regulated within limits shown above.* C. Replace thermocouple or thermopile.* D. Replace.* E. Blow dust or lint out of pilot.* F. Clean or replace pilot orifice.* G. Remove and clean all orifices.*
3.	Flame roll-out at start-up	A. Blocked flue. B. Pilot out of position (delayed ignition). C. Blocked heat exchanger. D. Refractory blanket out of place. E. Altered vent cap. F. Low gas pressure.	A. Remove blockage.* B. Correct pilot position.* C. Clean and correct as necessary.* D. Clean and correct blanket as necessary.* E. Install an unaltered factory approved vent cap.* F. Check and correct gas pressure.*
4.	Spillage at draft hood	A. Cold chimney. B. Vent pipe pitches down to chimney. C. Blocked chimney. D. Altered draft hood. E. Prefabricated chimney with incorrect cap.	A. Allow heater to operate five (5) minutes to create draft action. B. Reinstall vent pipe to pitch up from the heater to chimney.* C. Remove blockage.* D. Install factory-provided draft hood.* E. Install U.L. listed vent cap.*
5.	Lazy flame with yellow tip	A. Low primary air. B. Incorrect burner pressure.	A. Check for internal burner obstructions.* B. Adjust burner pressure according to rating plate.* Clean burner ports if dirty.*
6.	Not enough heat	A. Inadequate gas supply. B. Low burner gas pressure. C. Heater size inadequate. D. Low temperature rise.	A. Gas meter too small. Gas line from meter to heater too small.* B. Gas pressure on heater burner should be adjusted to the values list in Table 2.* C. Replace with heater of higher input.* D. Check and correct water flow.*
7.	Heater pounding or knocking	A. Inadequate water flow through heater.	A. Check temperature rise between inlet and outlet heater piping. See section 11.6 for recommended range of temperature rise. If temperature rise is above the maximum recommended, check for closed valve in system.*
8.	Heater condensing	A. Low water temperature.	A. Flue product moisture will condense at the start-up until the heater water temperature reaches the normal operating conditions.*
9.	Pressure relief valve opens	A. Restriction in water flow system at or downstream of heater.	A. Check for proper operation of all valves, bypass valve and any equipment between pool and heater outlet.*
10.	Pilot is lit but main burners will not come on	A. Gas valve not at "on" position. B. Hi-limit switches failed. C. Pressure switch failed or out of adjustment. D. Roll-out switch (fusible link) failed. E. Gas valve failed. F. Broken wire in thermostat circuit or defective thermostat. G. Heater wired incorrectly. H. Vent temperature limit failed.	A. Turn knob to "on" position. B. Investigate reason for overheating and replace hi-limit switch as necessary.* C. Adjust pressure switch (see Section 11.5) or replace as necessary.* D. Investigate reason for flame rollout and replace roll-out switch as necessary.* E. Check and replace gas valve as necessary.* F. Check continuity through thermostat circuit with wires disconnected.* G. Check heater wiring against wiring diagram in Section 6, correct as necessary.* H. Thoroughly investigate the causes for vent temp limit failure, correct the problem and replace the vent temp limit.
11.	Heater short cycles	A. Low water flow through heater. B. Failing hi-limit switch.	A. Increase size of pump or increase piping size.* B. Check hi-limit switches and replace as necessary.*

* Must be performed by a qualified professional pool technician.

Section 11. Professional Maintenance and Service

⚠ WARNING

SERVICING SAFETY

Some of the servicing procedures for the Legacy heater are hazardous because they involve fuel gas, electricity, moving parts and procedures which require testing or temporary bypass of safety controls. For this reason, the heater must be serviced only by a qualified professional service technician.

IMPROPER SERVICE HAZARD

The Legacy heater incorporates unique design features. Incorrect service of this heater can result in property damage, personal injury or death. To avoid such hazards, the heater must be serviced only by a qualified professional service technician.

11.1 General Information

A qualified professional technician must service the Legacy model LRZ millivolt pool heater using Zodiac service procedures. Before calling for service, however, the owner should check for obvious problems. The other components in the pool system, including pump, filters and strainers, water valves, gas supply and time clocks have an effect on heater operation.

Confirm that the Legacy heater control switch is set to 'ON' and that the temperature control knob is set high enough to make the heater operate. Make sure the pump is operating, that the filter and strainers are not clogged, that there are no mis-positioned water valves, that the gas is not shut off and that time clocks are properly adjusted. Also be sure that there is no blockage of the vent or louvers which supply combustion air to the burners.

11.2 Natural-Draft Combustion System

The Legacy model LRZ millivolt pool heater has an atmospheric combustion system. This system is illustrated in Figure 24.

As the heated exhaust gases rise out of the combustion chamber, flow is created through the system and fresh combustion air is drawn into the heater through the louvers cut into the front and sides of the heater. Gas is forced through an orifice into the open end of a burner. When the gas flows into the burner, a “negative” pressure is created at the opening of the burner. This negative pressure pulls air into the burner with the gas and mixes the two together. As the gas/air mixture flow through the burner ports it is ignited in the combustion chamber. Hot combustion products then rise through a highly efficient heat exchanger. Combustion products then enter a flue collector and are directed to the outdoors through the grate top of the heater or a vent pipe and cap.

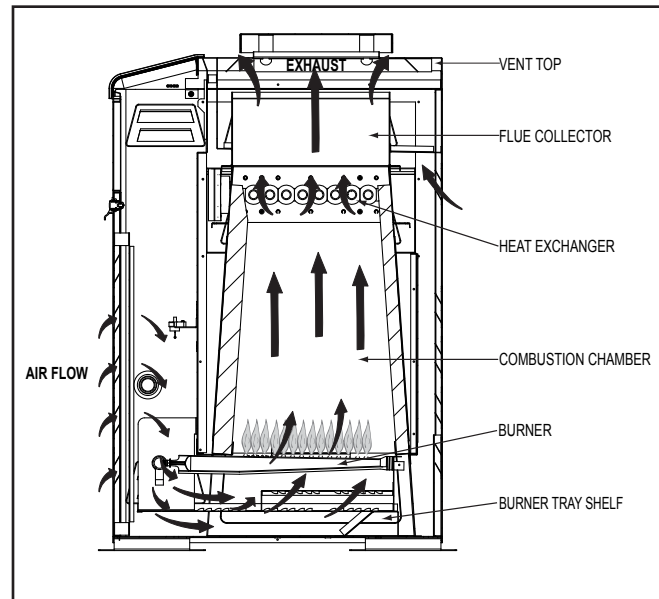

Figure 24. Atmospheric Combustion System

11.3 Heater Components and Their Operation

1. **Gas Valve / Regulator** - The gas valve controls gas flow into the burner. It provides flow only when the temperature controls require heat and only if all safety controls enable operation. It is also a *positive pressure regulator*. It regulates the gas pressure in the burner to specifications addressed earlier in this manual. This is necessary for proper operation of the burner system.
2. **Temperature Control** - The Zodiac Legacy pool/spa heater is controlled by a mechanical thermostat which controls heater operation to bring the water to the desired temperature. The desired temperature is set by rotating a knob on the face of the control panel. To achieve accurate water temperatures, the pool/spa water must be monitored with an accurate pool thermometer.
3. **Pilot/Pilot Ignition** - The Legacy heater relies on a standing pilot to ignite the burners when the temperature control calls for heat. When lit, the pilot receives a constant flow of gas from the gas valve. If the pilot extinguishes, the gas valve is automatically signalled to stop the flow of gas to the pilot and the burners to prevent a gas build up in the heater. Igniting the pilot is achieved by means of a piezo spark igniter mounted on the inner front panel of the controls compartment of the heater.
4. **Pilot Generator (Thermopile)** - The pilot generator is a device, that when heated by the flame of the pilot, generates a small electrical voltage of approximately 750 millivolts. The voltage is placed across the temperature controller and safety circuit of the heater. If this current is

broken at any time, the gas valve is immediately shut off and the heater stops firing. This voltage is also used to activate the gas valve's pilot coil which allows gas to flow to the pilot after the gas valve knob is released.

4. **Thermocouple** - The thermocouple is a device that senses if the pilot flame is hot enough to ignite the gas fuel from the burner. If hot enough, the main gas valve is allowed to open. If the thermocouple does not sense enough heat from the pilot flame (such as when the pilot is out), then the thermocouple shuts off the gas valve to the burners.
5. **Limit Switches** - Two (2) limit switches prevent excessive water temperature - one (1) within the heat exchanger and one (1) for water leaving the heater. If either senses excessive temperature, burner operation is interrupted.
6. **Water Pressure Switch** - This control senses whether or not water is available to the heater by measuring back pressure inside of the heat exchanger. If the pool water pump fails or the water filter is blocked, the pressure switch prevents operation of the burner.
7. **Roll-Out Switch (Fusible Link)** - This is a single-use switch which detects abnormal temperature in the component vestibule. It is a roll-out switch (fusible link) which is held to the inner panel just above the burner tray by a sheet metal bracket. Excessive temperature in the component compartment, possibly due to a blocked flue or flame roll-out, will cause the link to fail. This opens the safety circuit which shuts off the gas valve and shuts the heater down.
8. **Vent Temperature Limit** - This is a single-use switch which detects abnormal temperature in the vent system. It is mounted to the flue collector assembly. Excessive temperatures will cause the switch to open. Excessive temperatures can be caused by inadequate water flow or a damaged heat exchanger. The vent temperature limit will open the safety circuit which shuts off the gas valve and shuts down the heater.

11.4 Electrical Troubleshooting

This section describes procedures for checking the pilot generator and control components of the heater one at a time and in the order they appear in the control circuit.

NOTE Pump must be running during the troubleshooting procedure.

These procedures require a voltmeter with a minimum 0-1000 mVDC range. Figure 25 shows the pilot generator and control circuits, and where to take measurements. Location numbers and letters in circles have been added, and will be referenced in the follow-

ing sections.

As stated at the beginning of this manual, some of these procedures are hazardous. Only a qualified service technician should service the heater.

During the trouble shooting procedure, the filter pump must be on, the pilot on the heater must be lit, the ON/OFF switch on the heater must be in the ON position and the control knob must be turned to the maximum setting so that there is a call for heat. We recommend turning the gas valve control knob to the "PILOT" position to prevent the main burners from firing throughout the procedure. Before starting the procedure, be sure that the pilot has been lit for at least two (2) minutes and that the pilot generator (thermopile) is positioned correctly within the flame of the pilot.

The pilot generator also operates the pilot coil of the gas valve, allowing gas to flow to the pilot when the gas valve knob is released from the pilot lighting position (see Section 8.3 "Lighting and Shutdown Procedures"). If the pilot will not stay lit when the gas valve knob is released, check the pilot generator output as described in Section 11.4.2 and replace if necessary. If the pilot generator output is sufficient, then check the gas valve as outlined in Section 11.4.1.

11.4.1 Gas Valve

The gas valve consists of two (2) separate internal operating valves. The main valve supplies gas to the main burners for heater operation. The pilot valve supplies gas to the pilot when the pilot generator activates the pilot coil.

If the pilot will not stay lit after following the lighting instructions in Section 8.3, check for the following:

- Pilot generator output
- Correct type of gas supplied
- Correct gas supply pressure
- Air in the gas line
- Pilot coil wire connections clean and tight
- Faulty thermocouple

If the pilot will not stay lit after checking the items listed above, the pilot coil may be causing the fault. Replace the gas valve.

If the main burners will not light after following the lighting instructions in Section 11.4.2, check the voltage reading between the PP terminal on the gas valve (test point 1) and the TH terminal on the gas valve (test point 17). If the meter shows less than 220mVDC then there is a problem with the pilot generator, the sensors in the safety loop or the control panel. Follow the trouble shooting procedure as outlined in sections 11.4.2 through 11.4.7.

If the meter shows more than 220mVDC at test point 17, then check for the following:

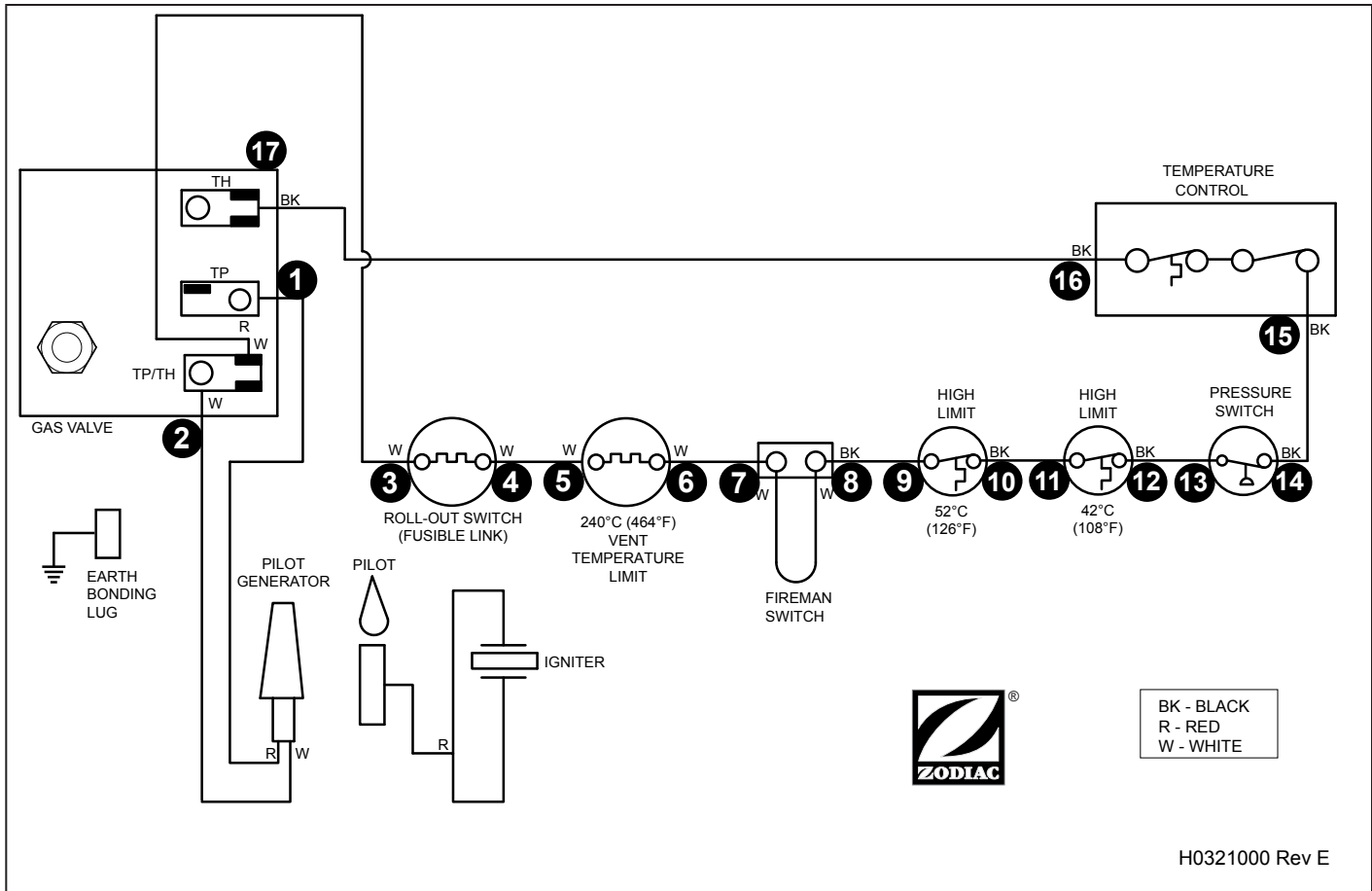

Figure 25. Test Point Identification Diagram

- Correct type of gas supplied
- Correct gas supply pressure
- Correct gas burner pressure
- Correct orifice size
- Air in the gas line

If the main burners will not stay lit after checking the items listed above, the gas valve may be causing the fault. Replace the gas valve.

11.4.2 Pilot Generator

The pilot generator generates a 700-750mVDC signal when heated by the pilot flame. When the pilot generator is connected to the heater's control components, there will be some voltage drop in the circuit so that the measured voltage will be less than 750mVDC. But the measured voltage should never be below 500mVDC when the ON/OFF switch is in the "OFF" position or 220mVDC when the ON/OFF switch is in the "ON" position.

With the pilot generator connected to the gas valve and the ON/OFF switch in the OFF position, place the red lead of the voltmeter on the TPP terminal (test point 1) of the gas valve. Place the black lead of the meter on the TPP/TH terminal (test point 2) of the gas valve. The meter should show a minimum of 500mVDC. If the meter show less than 500mV, check for partial shorts, loose or corroded connections or partially broken wires between the pilot generator and the gas valve.

If the wires and connections are sound, check the pilot generator output. You will need alligator clips to do this. Disconnect the pilot generator from the gas valve. The pilot will go out. Light the pilot while pressing down on the gas valve control knob. Continue holding the knob for at least one (1) minute. Immediately measure the voltage between the two (2) wires of the pilot generator. If the meter does not show at least 700mV, replace the pilot generator.

11.4.3 Roll-Out Switch (Fusible Link)

Check the voltage going to the safety circuit. Be sure that the pilot generator is correctly wired to the gas valve, the pilot is lit and the control knob on the gas valve is in the "PILOT" position. Leave the red voltmeter lead in place at test point 1. Touch the black lead of the meter to the terminal of the roll-out switch (fusible link) where the white wire from the gas valve is connected (test point 3).

If no voltage is detected at test point 3, the wire between the gas valve and the roll-out switch (fusible link) is broken. Replace the wire.

If there is a minimum of 220mV at test point 3, move the black meter lead to the other terminal of the roll-out switch (fusible link) (test point 4).

If no voltage is detected at test point 4, the

roll-out switch (fusible link) has failed. This indicates higher than normal temperatures in the component compartment (vestibule). Normal component compartment temperature is well below 148.9°C (300°F). The roll-out switch (fusible link) is designed to fail at temperatures above 151.7°C (305°F). Excessive temperature might be due to a blocked flue or heat exchanger. Clean the heat exchanger and clear the flue and vent of any restrictions. Sometimes the roll-out switch (fusible link) fails due to flame roll-out. Flame roll-out may be caused by delayed ignition or downdrafting in windy areas. Thoroughly investigate the causes for flame roll-out and correct the problem when replacing the roll-out switch (fusible link).

Check the voltage going to the vent temperature limit. Leave the red voltmeter lead in place at test point 1. Touch the black lead of the meter to the terminal of the vent temperature limit where the white wire from the roll-out switch (fusible link) is connected (test point 5).

If no voltage is detected at test point 5, the wire between the roll-out switch (fusible link) and the vent temperature limit is broken. Replace the wire.

If there is a minimum of 220mV at test point 5, move the black meter lead to the other terminal of the vent temperature limit (test point 6).

If no voltage is detected at test point 6, the vent temperature limit has failed. The vent temperature limit will fail due to abnormal temperatures in the vent system. Excessive temperatures will cause the switch to open.

The vent temperature limit is designed to fail at temperatures above 464°F (240°C). Excessive temperatures can be caused by inadequate water flow or a damaged heat exchanger. Thoroughly investigate the causes for vent temperature limit switch failure and correct the problem when replacing the vent temperature limit.

11.4.4 Fireman Switch and External Interlocks

Check the voltage going to the external device. Touch the black lead of the meter to the fireman switch terminal strip where the white wire from the roll-out switch (fusible link) is connected (test point 7). The meter should read at least 220mV. If the voltage is less than 220mV, there may be a bad connection or wire between the roll-out switch (fusible link) and the terminal strip. The wire may need to be replaced. If voltage of 220mV or more is detected at test point 7, move the black lead of the meter to the fireman switch terminal strip connection where the white wire from the high limit is connected (test point 8). The meter should read at least 220mV. If there is no voltage, the time clock switch or other external interlock may be mis-adjusted, mis-connected or defective. Correct this external problem.

11.4.5 Limit Switches

Since the limit switches are not easily accessible, you can check the voltage going into the component after the limit switches in the circuit. If voltage is detected there, then the limit switches are closed and are operational.

Check the voltage going to the water pressure switch. Leave the red voltmeter lead in place at test point 1. Touch the black lead of the meter to the terminal of the water pressure switch where the black wire is connected (test point 13).

If the voltage is less than 220mV, there may be a bad connection, a partial short or a faulty sensor. If there is no voltage, one of the limit switches is open. This is normally due to excessive water temperature, which should be thoroughly investigated before replacement of limit switches. Excessive water temperature may be caused by low water flow. Water flow deficiency may be due to obvious problems such as a defective pump or blocked water filter. Alternatively, excessive water temperature may be due to over-firing, or to a problem with the water piping or the heater's internal bypass control. Over-firing might be a result of an incorrect gas orifice or supply of propane gas to a heater intended for natural gas.

If there are no such fundamental problems, identify which of the switches is open. Limit switch access is through the limit switch plugs on the inlet/outlet header. Remove the limit switch plugs from the bottom of the header and gently remove the limit switches from the wells. Move the black lead of the meter to the terminal on the 42°C (108°F) limit switch (test point 9) that is connected to the fireman switch terminal block. Less than 220mV at this point means that the wire between the terminal block and the limit switch has a poor or broken connection or a partial short. Replace the wire assembly. If at least 220mV is detected at test point 9, then move the black lead of the meter to the other terminal of the 42°C (108°F) limit switch (test point 10). Low or no voltage here means that the limit is open and must be replaced.

If 220mV or more is detected at test point 10, move the black lead of the meter to the terminal on the 52°C (126°F) limit switch (test point 11) that is connected to the 42°C (108°F) limit switch. Less than 220mV at this point means that the wire between the two limit switches has a poor or broken connection or a partial short. Replace the wire assembly. If at least 220mV is detected at test point 11, then move the black lead of the meter to the other terminal of the 52°C (126°F) limit switch (test point 12). Low or no voltage here means that the limit switch is open and must be replaced. If voltage is detected at test point 12, move the black lead of the meter to the terminal of the water pressure switch where the black wire from the high limits is connected (test point 13).

Less than 220mV at this point indicates that the wire connecting the high limits to the water pressure switch is faulty or poorly connected. Correct the problem or replace the wire.

NOTE The limit switches have different trip points, and it is important that replacements are correct. The 42°C (108°F) switch has a red dot on the top of the switch, and must be installed in the inlet side of the header. The 52°C (126°F) switch has no dot and must be installed in the outlet side of the header in the well farthest from the heater jacket.

11.4.6 Water Pressure Switch

If the meter shows at least a 220mV signal at test point 11, move the black lead of the meter to the other terminal on the water pressure switch (test point 14).

If there is no voltage, the pressure switch contacts are open. This is almost always due to a water flow deficiency, the most common one being a blocked water filter or defective pump. However, sometimes it is due to blockage of the copper tube or mis-adjustment of the switch. Investigate thoroughly, referring to Section 11.5 "Adjusting the Water Pressure Switch". If there is no problem with the pool system or pressure switch adjustment, replace the pressure switch.

11.4.7 Temperature Control Circuit

The temperature control circuit consists of two (2) major components which must all be working correctly for the signal to be transmitted to the gas valve. The components are the ON/OFF toggle switch and the mechanical thermostat. Use the following procedure to check each component for functionality.

Check the temperature control as a complete circuit before checking each component individually. With the red lead of the meter still at test point 1, place the black lead of the meter on the back of the mechanical thermostat (test point 16). If the meter shows more than 220mV at the pressure switch (test point 14) but not at test point 16, then one of the components of the temperature control circuit is faulty. Proceed with the following sections to test the components.

11.4.7.1 ON/OFF Toggle Switch

Remove the temperature control panel from the bezel on the front of the heater to gain access to the switch. Be sure that the toggle switch is in the "ON" position. Place the black lead of the meter on the toggle switch terminal (test point 15) that is connected to the pressure switch. Less than 220mV at this point indicates that there is a problem with the black wire that connects the pressure switch to the toggle switch. If at least 220mV is detected at test point 15, move the black meter lead to the other terminal on the toggle switch (test point 16).

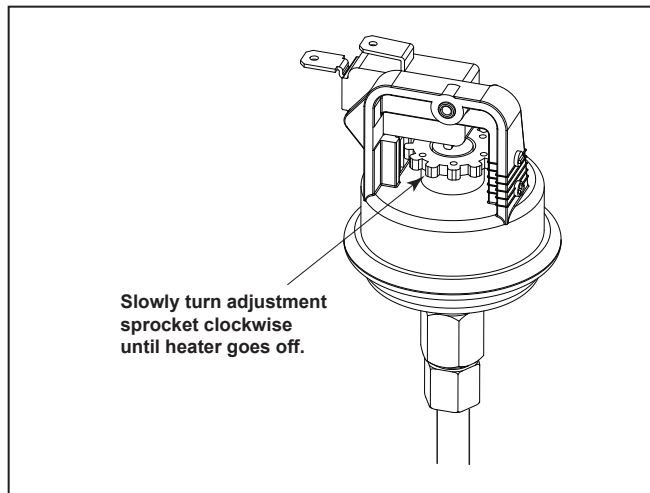

Figure 26. Pressure Switch Adjustment

A reading of less than 220mV here indicates a faulty switch. If the reading is more than 500mV, turn the switch "OFF" and then "ON" again to be sure that the internal contacts are working correctly. The volt meter reading should drop to zero when the switch is "OFF" and return to at least 220mV when the switch is placed back in the "ON" position.

11.5 Adjusting the Water Pressure Switch

⚠ CAUTION

The water pressure switch should be adjusted to turn the heater off when the pump is off. Setting the switch to close at too low of a flow can damage the appliance. Adjust the switch to turn the heater off, not on.

The pressure switch is preset at the factory for activation at 14 kPa. Do not adjust the pressure switch if the heater is installed more than 4.57 m below the pool surface. Consult your local Zodiac representative for recommendations.

On some installations, the piping from the heater to the pool is very short. The back pressure could be too low to trigger the pressure switch. If this happens, it may be necessary to install a directional fitting or elbows where the return line enters the pool. This will increase back pressure enough for the heater to operate properly.

Make sure the pool filter is clean before making any pressure switch adjustment. A dirty filter will restrict the water flow and the pressure switch cannot be adjusted properly.

To adjust the pressure switch, refer to Figure 26 and proceed as follows:

1. Turn the heater control to OFF. See Figure 20.
2. Remove the side panel above the front header to access the water pressure switch.

3. Start the filter pump and confirm by means of a voltmeter that the pressure switch closes (if the switch fails to close, replace it with a switch that has a lower minimum setting).
4. Set the temperature control to the max position. Heater should start.
5. With your fingers, turn the adjustment sprocket very slowly clockwise until the heater goes off.
6. Slowly turn the pressure switch adjustment sprocket **counterclockwise** one-quarter turn. The heater should come back on.
7. Check the adjustment by turning the filter pump OFF. The burners should shut off immediately. If they do not, restart the filter pump and repeat Steps 5 and 6. Check the adjustment again.
8. Return the pool temperature control to the desired temperature.

It may be necessary to repeat these steps to get a proper setting. The switch must be set so that the heater will not fire unless the pump is running. If a proper setting cannot be reached, contact the factory service department.

11.6 Temperature Rise

The Legacy pool and spa heaters have an internal bypass which accommodates a wide range of water flow. The bypass is easily adjustable to change the temperature rise for optimum performance and length of heater life. The bypass assures constant heat exchanger flow even though flow through the filter system will vary depending on how dirty the filter is.

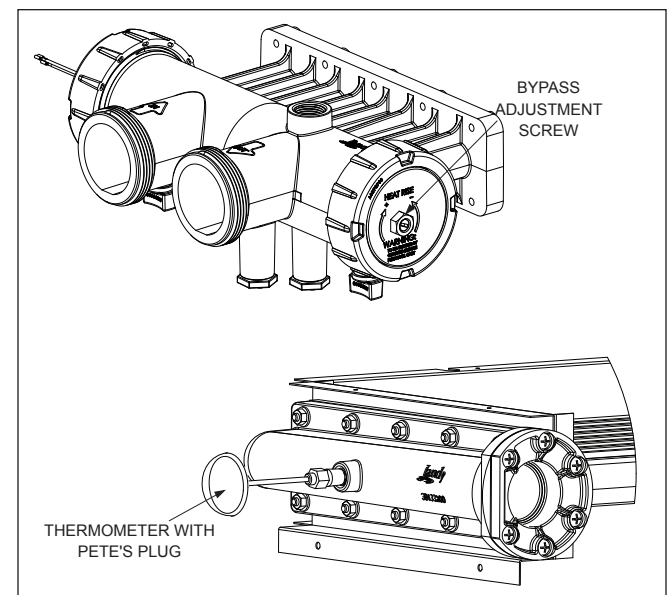

Figure 27. Temperature Rise Measurement

For most installations, an external bypass valve is not needed in the heater water piping. This is due to the large size of the heater's internal bypass valve. If the pump flow rate is known to exceed 470 lpm, an external bypass may be needed to assure proper heater operation.

Water flow should be confirmed upon start-up of the heater and in most servicing situations. If the flow is not normal, corrections must be made to the pool system. Flow is evaluated by determining the water temperature rise through the heat exchanger.

Before checking the temperature rise, make sure that the pool filter is clean and that gas supply and burner pressures are correct. If necessary, clean all components of the filter system. Temperature rise is measured in the return header of the Legacy. To measure the temperature rise, turn off the filter pump and remove the plastic plug protruding through the cabinet on the return header side of the heater. See Figure 27. With the plug removed, install the special thread adapter and Pete's Plug® fitting and insert a pocket thermometer. A temperature rise measurement kit is available through your Zodiac distributor. See Section 12 of this manual for the correct kit number.

The internal bypass can be adjusted by means of a screw on the right-hand side of the header. To adjust the temperature rise to within the ranges specified in Table 7, proceed as follows:

1. If the piping system has an external bypass valve, close it.
2. Turn the heater control panel to OFF.
3. Start the filter pump.
4. After three (3) minutes, note and record the thermometer reading. This is the pool water temperature.
5. Start the heater by turning the controller to ON. Allow the heater to operate for five (5) minutes or more. Note and record the thermometer reading. Subtract pool water temperature from this reading. This difference is the temperature rise. Refer to Table 6. If your measured temperature rise is within the range designated for your heater, skip steps 6 through 8.
6. Locate the bypass adjustment screw on the right-hand side of the header (see Figure 22). Loosen the nut so that the screw can be adjusted. A slight water leak past the nut may be expected. Turn the screw counterclockwise to decrease the temperature rise, and clockwise to increase the temperature rise as needed to achieve the ranges in Table 6. After the adjustment, tighten the nut so that no leaks occur.
7. If the temperature rise is too low and cannot be raised by means of the adjustment screw, the flow is in excess of 470 lpm. An external bypass will need to be installed, or if one already exists, open the external bypass valve gradually until the temperature range in Table 6 is achieved.
8. If it was necessary to adjust the external bypass as outlined in step 7, scribe a line on the bypass shaft and case to mark the correct adjustment position. Wire or remove the valve handle to prevent tampering.

Table 6. Water Temperature Rise and Flow Rates (Measured at Return Header)

Model	Minimum Temp Rise, °C (°F)	Maximum Temp Rise, °C (°F)	Minimum System Flow lps (GPM)
125	4 (7)	5 (10)	1.9 (30)
175	6 (10)	7 (13)	1.9 (30)
250	9 (16)	11 (20)	1.9 (30)
325	11 (20)	14 (26)	1.9 (30)
400	13 (23)	16 (29)	1.9 (30)

In a system without external bypass, it may be necessary to make changes. If temperature rise is too low, a manual bypass must be installed. If temperature rise is too high, there is inadequate flow, possibly requiring a change to the piping system or a larger pump. Before proceeding with either remedy, verify proper heater operation. Low gas input results in low temperature rise and vice-versa. A problem with the heater internal bypass assembly also affects measured temperature rise.

Section 12. Replacement Parts

12.1 Ordering Information

To order or purchase parts for the Legacy pool and spa heater, contact your nearest Zodiac dealer or distributor. See the Zodiac web site at www.Zodiac.com for the nearest service center. If they cannot supply you with what you need, contact Technical Support at Zodiac, telephone (800) 822-7933.

NOTE To supply the correct part it is important that you state the model number, serial number and type of gas when applicable. This information is on the rating plate inside the heater.

The following pages contain a parts list, general exploded view, and detailed exploded views to aid in parts identification. Please refer to these pages when ordering parts for your Legacy pool/spa heater.

12.2 Parts List

Key No.	Description	Model No.	Order Part No.	Key No.	Description	Model No.	Order Part No.
Pilot/Igniter System				44	Adapter Plate	125-400	R0478301-05
1	Pilot, Main Burner Assembly, Natural	All	R0522101	45*	Clip	All	R0500200
1	Pilot, Main Burner Assembly, LPG	All	R0522102	46	Vent Temp Limit Switch Assembly	All	R0543101
2	Pilot Burner, Natural	All	R0522201	47	Vent Temp Limit, 240°C (464°F)	All	R0524300
2	Pilot Burner, LPG	All	R0522202	Water System			
3	Burner, Main w/ Pilot Bracket	All	R0522300	48	Inlet/Outlet Header Assy, Polymer	All	R0470800
4*	High Voltage Lead Assembly	All	R0493400	49	Return Header Assy, Polymer	All	R0454201
5	Piezo Lighter Assembly	All	R0355900	50*	Header Hardware Set, Polymer	All	R0454500
Main Gas Assembly				51	Heat Exchanger Assembly, Complete	125-400	R0485706-10
6	Burner Tray Assy, Natural Gas	125-400	R0484701-05	52	Heat Exchanger Drain Plugs (2), Polymer	All	R0446000
6	Burner Tray Assy, LPG	125-400	R0484801-05	53	3" Coupling Nut Kit w/ O-ring	All	R0454000
7	Burner Tray, Shelf Only	125-400	R0469101-05	54	Bypass Assembly, Polymer	125-400	R0453701
8	Gas Valve, Natural	125-400	R0486600	55	Bypass Spring, Adjustable, Polymer	All	R0453901
8	Gas Valve, LPG	125-400	R0546500	56	Tailpiece w/ Union Nut (Set of 2), 50mm	All	R0472800
9	Manifold Assy, Natural Gas	125-400	R0485901-05	57	Header Gasket Assembly (Set of 18)	All	R0454300
9	Manifold Assy, LPG	125-400	R0486001-05	58*	Bypass Hardware, Gaskets	All	R0453800
10	Anti-Rotation Bracket	All	R0485200	59	Heat Exchanger Tube Assy, Copper	125-400	R0490101-05
11	Burner, Main	All	R0469800	60	Plug Sensor	All	R0456800
12	Burner Manifold	125-400	R0485101-05	Firebox Components			
13	Gas Orifice, Natural	All	R0469200	61	Combustion Chamber Panels	125-400	R0494906-10
13	Gas Orifice, LPG	All	R0469500	Jacket Components			
14	Gas Valve Fitting	All	R0485300	62	Door with Latch	125-400	R0470901-05
Electrical System				63	Latch Assembly	All	R0334900
15	Temp Control/User Interface	All	R0471902	64	Grommet, Sealing, 2"	All	R0460300
16	Temp Control/User Interface w/Housing	All	R0491701	65	Grommet, 7/8"	All	R0492800
17*	Wire Harness Set	All	R0490400	66	Rear Panel Assy	125-400	R0482301-05
18	On-Off Switch	All	R0099800	67	Side Panel, Right	All	R0482400
19	Temperature Control Label	All	R0490500	68	In/Out Cover Panel, Top	All	R0482500
20	Temperature Control with Sensor	All	R0318800	69	In/Out Cover Panel, Bottom	All	R0482600
21	Temperature Control Bulb Gasket	All	R0456600	70	Side Panel, Left	All	R0482700
22	Thermostat Knob, Black	All	R0010700	71	Return Side Cover, Top	All	R0482800
23	Stop Plate, "Temp-Lok"	All	R0472200	72	Return Side Cover, Bottom	All	R0482900
24	Temperature Control Plate Assembly	All	R0472002	73	Heat Shield	125-400	R0483101-05
25	Stop Plate Screw	All	R0474600	74	Heat Deflector Guard, Front	125-400	R0483201-05
26	Temperature Sensor Plug	All	R0456800	75	Rear Partition	125-400	R0483401-05
27	Water Pressure Switch Tubing	All	R0483600	76	Heat Deflector Guard, Rear	125-400	R0483501-05
28	Pressure Switch, 2 PSI	All	R0013200	77	Controller Mounting Panel	125-400	R0483901-05
29	Cap, Sensor and Pressure Switch w/ O-ring	All	R0455400	78	Plug, Button, 7/8"	All	R0491100
30*	Pressure Switch, 1-10 PSI	All	R0015500	79	Weather Stripping	All	R0491000
31	High-Limit Switch Assembly	All	R0514002	Optional Components			
32	High-Limit Switch, 42°C (108°F)	All	R0514200	80*	Noncombustible Base	125-400	R0471001-05
33	High-Limit Switch, 52°C (126°F)	All	R0514300	81*	Press Relief Valve Kit, 75 PSI, Polymer	All	R0336100
34	Roll-Out (Fusible Link) Assembly	All	R0012200	82*	Temp Rise Measurement Kit	All	R0336000
35	Roll-Out (Fusible Link) Bracket	All	R0337200	NOTES:			
36	Terminal Block	All	R0097800	1. All hardware sets contain all pieces necessary for assembly, including gaskets.			
37	Nut, Sensor Retainer	All	R0523900	2. Gaskets and hardware are included in all kits that involve the removal of a gasket as part of the procedure to replace a part.			
Vent System				* PARTS NOT SHOWN ON KEY VIEW			
38	Top Enclosure	125-400	R0470301-05				
39	Vent Cover	125-400	R0470401-05				
40	Rainshield (Partition)	125-400	R0478201-05				
41	Flue Collector Assembly	125-400	R0470501-05				
42	Outdoor Vent Cap	125-175	R0491606				
42	Outdoor Vent Cap	250-400	R0491603-05				
43	Indoor Draft Hood	125-175	R0499606				
43	Indoor Draft Hood	250-400	R0499603-05				

12.3 General Exploded View

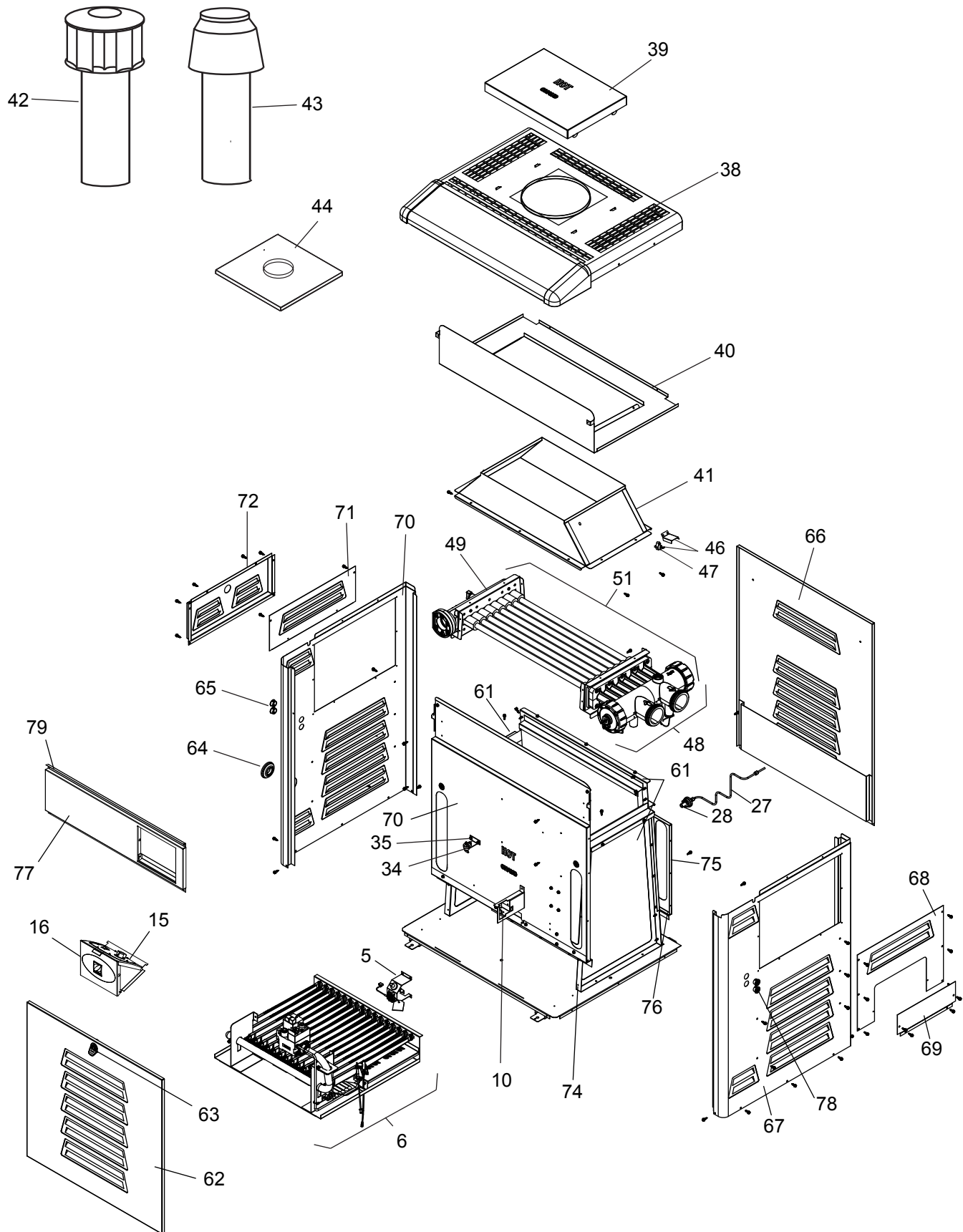

12.4 Detailed Exploded View

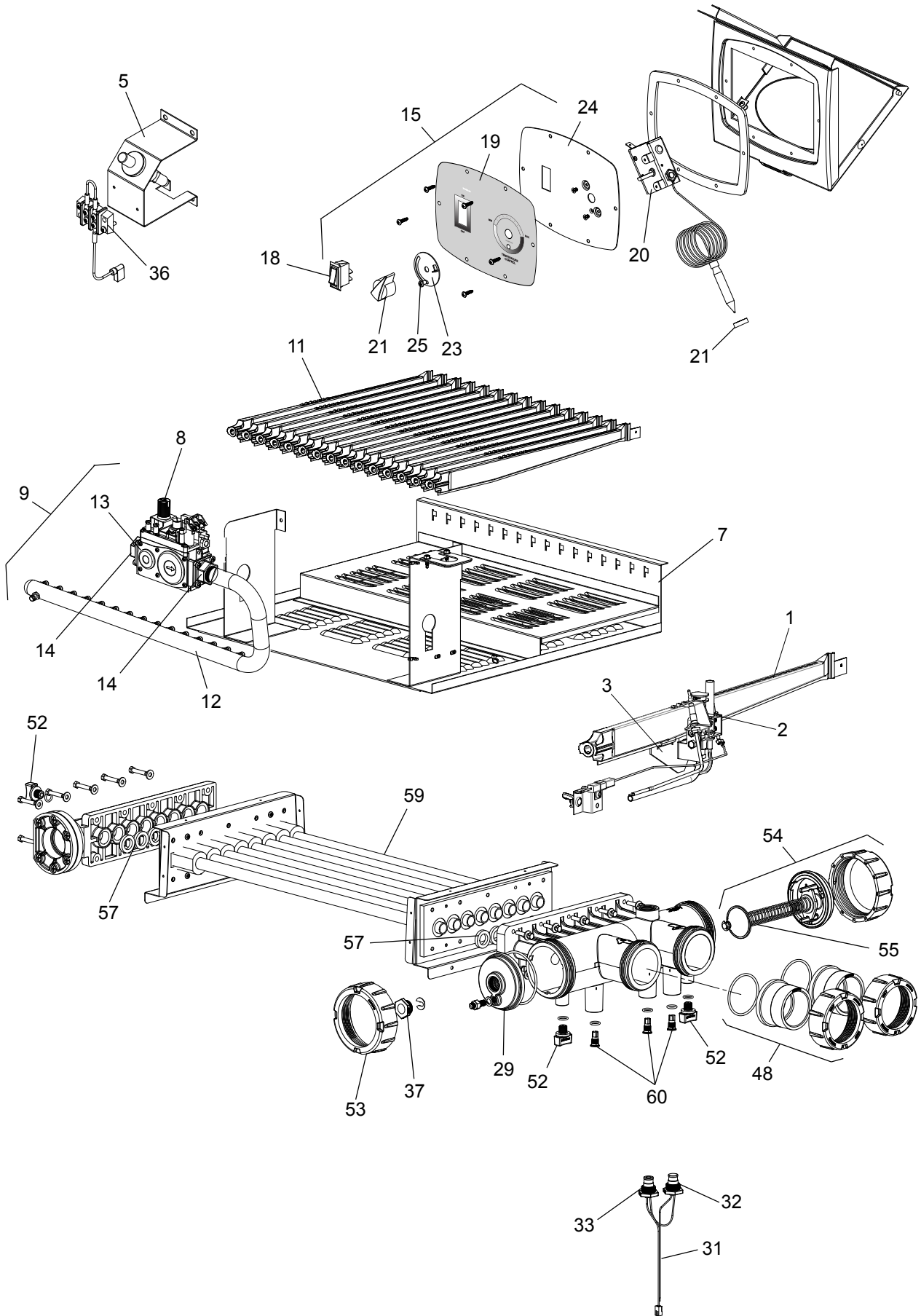

Zodiac Pool Systems, Inc.

2620 Commerce Way, Vista, CA 92081

1.800.822.7933 | www.ZodiacPoolSystems.com

*ZODIAC® is a registered trademark of Zodiac International, S.A.S.U., used under license.
All trademarks referenced herein are the property of their respective owners.*

©2012 Zodiac Pool Systems, Inc. H0316500 Rev F 1204



ZODIAC®