

Caretaker[™]

IMPORTANT SAFETY INFORMATION

When installing and using this equipment, basic safety precautions should always be followed including the following:

READ AND FOLLOW ALL INSTRUCTIONS.

Installation of electrical equipment should be performed by a licensed electrician and conform to all National Electric Code (NEC), state and local law, ordinances, codes and regulations.

WARNING: To reduce the risk of electrical shock:

- Install all electrical equipment at least 10 ft. (3 m) from inside wall of pool or spa.
- Disconnect power before servicing this equipment.
- CAUTION: Use supply wires suitable for 140-167°F (60/75° C).
- CAUTION: Connect only to a circuit protected by a Class A ground fault circuit interrupter.
- Use copper conductors only.

WARNING: To reduce risk of injury, do not permit children to use this product unless they are closely supervised at all times.

To guarantee complete cleaning and qualify the warranty, fax or email a Design Fact Sheet along with a scaled pool plan for FREE In-Floor Design Service.

Email: design@zpc.zodlac.com

Fax: (760) 597-1246

If the pool design or dimensions change during excavation, a new design plan must be drawn.

Install the valve above ground and finished pool water level. **Do not bury valve after installation.**

Install cleaning heads and nozzles according to the Design Plan.

If pool includes an elevated spa, install a check valve on the line feeding the spa heads to avoid spa draining. Install other check valves (as normal) to avoid spa return jets and suction lines from draining.

SAVE THESE INSTRUCTIONS.

For customer service or support:

- For on-line support: www.zodiacpoolsystems.com
- To contact Zodiac: **US and Canada**
Customer Service
2620 Commerce Way
Vista, CA 92081-8438
1-800-822-7933

Introduction

The Zodiac Caretaker in-floor pool cleaning system has two valve options: the **5-Port** valve and the electronically-driven **UltraFlex® 8-Port** valve which provides multiple timer capabilities.

Caretaker 5-port valves are sealed at the factory, ready for installation without adjustment.

Only a trained technician or licensed electrician should install the motorized UltraFlex 8-Port valve. Installation should follow National Electric Code (NEC) guidelines and comply with all local laws, ordinances, codes and regulations.

Failure to follow recommended installation methods could void warranties and cause injury.

Components

5-Port Valve

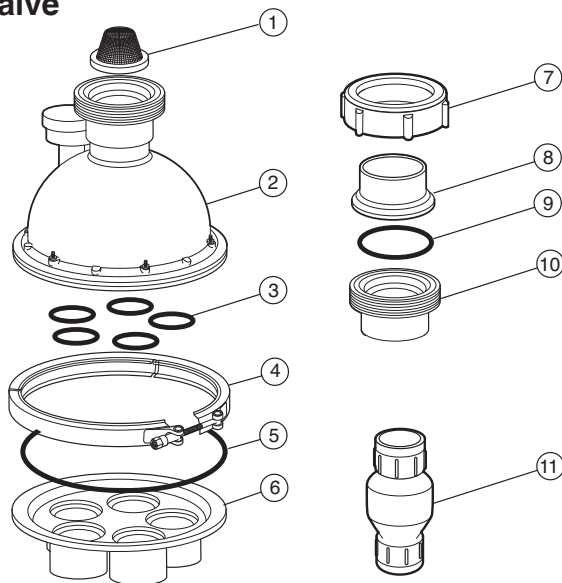

1. Dome Strainer
2. 5-Port Valve with Pressure Gauge
3. Port O-Ring (5)
4. V-Clamp
5. Bottom Plate O-Ring
6. Bottom Plate
7. Union Nut (2)
8. Union Adapter (2)
9. Union O-Ring (2)
10. Threaded Union Adapter (2)
11. Pressure Relief Valve

UltraFlex 8-Port Valve

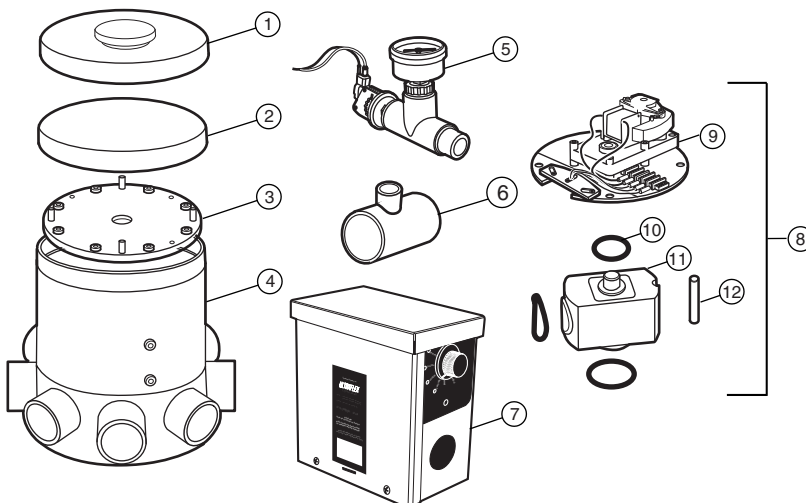

1. Valve Lid
2. Valve (Test Housing) Cover
3. Top Plate
4. UltraFlex 8-Port Valve Housing
5. Pressure Switch/Gauge Assembly
6. 2 in. x 3/4 in. Tee
7. UltraFlex Controller
8. Start Up (Motor) Kit
9. Motor Assembly with Sensor Plate
10. Tee Assembly O-Ring (3)
11. Tee Assembly
12. Wear Bar

Installation

1

Site Planning

Verify that the excavated pool matches the Zodiac Certified Pool Plan. Check the break, width, depth and designated step/bench locations. Zodiac design dimensions are from **finished** pool, not excavation. **If any dimensions have changed, a new plan must be drawn to ensure cleaning and warranty.**

Position the valve as close as possible to the swimming pool or water feature to reduce piping and improve performance. Valve must be at least 5 ft. away from the water's edge.

Install the valve so that the bottom housing and outlet ports are above ground and the finished pool water level. If a below water level installation is necessary, check valves or manual valves on the inlet and outlet ports will be required to prevent flooding of the valve.

Layout system so feed pipes enter the pool in the center of the wall closest to the pool equipment and valve. Use a check valve on the feed line in elevated spas to prevent draining.

Follow the design plan to position and stake the cleaning head locations. Each head has a designated nozzle that has a precise cleaning radius. Perimeter heads have a one foot overlap. Mark the cleaning radius around each stake to verify cleaning coverage.

2

Plumbing the System

Feed Pipes

The Zodiac certified plan indicates which cleaning heads will be plumbed together to form a bank. Run all feed lines to the top of the bond beam to facilitate easy valve hookup. Number the lines according to the design plan.

- Excavate niche in pool wall, 6 in. x 24 in. down to the pool floor
- Make line trench depth sufficient to cover all pipes
- Do not cross lines in floor
- Use 2 in. Schedule 40 pipe
- Position so feed line stub-ups are perpendicular to the slope of the finished pool floor

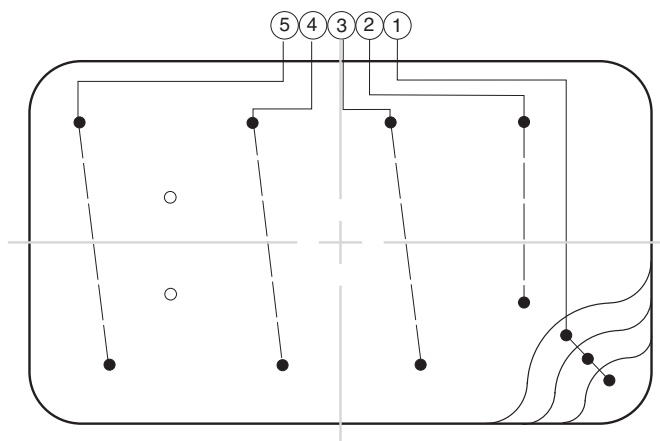

For Vinyl Liner Pools:

- Stake but do not plumb lines until walls are set, plumbing lines are fed under walls
- Vinyl collars are not adjustable, stub-ups **must be** perpendicular to finished pool floor
- Dig trenches 8 in. below excavation grade to accommodate setting of fittings

Cleaning Head Risers

The cleaning head collars require 2 ½ in. Schedule 40 risers. Use the Prefab Riser (part #5-9-150), a preassembled, capped reducer/riser that glues directly into the 2 in. tee, 90-degree elbow or coupling on the feed lines.

Valves

Install the non-functioning test housing (5-Port Test Housing, part #4-9-2002 purchased separately) for setup and pressure testing during the construction phase. The functional valve is installed at startup.

5-Port:

Plumb the pressure relief valve in a bypass line off the pool return line. Use two 2-way valves (one on return line, one on valve feed line) to control flow. Use the 2 in. unions included to install a removable section of pipe immediately before the valve to provide service access to the valve cup screen.

The bottom plate of the valve is made of a hard fiberglass filler and must be primed heavily before gluing. Connect the water source from the pool pump to the valve inlet.

Position the large o-ring in the bottom plate, align the guide pin and use the V-clamp to attach the plate to the test housing. Tighten the V-clamp until ends are about ¾ in. apart.

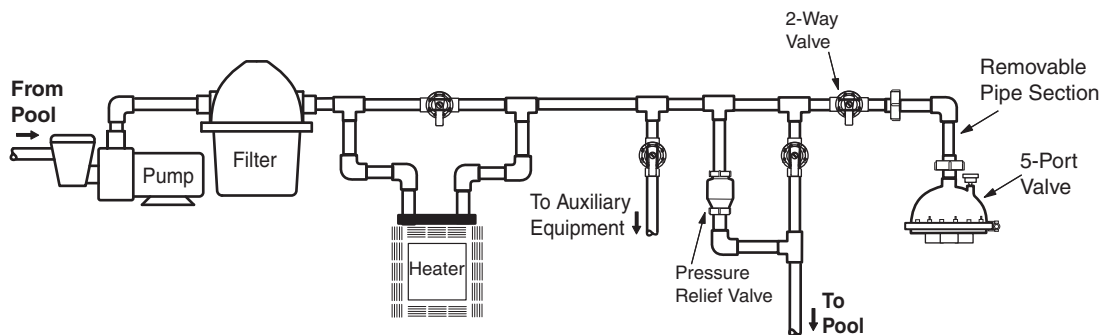

UltraFlex 8-Port:

Plumb the pressure switch/gauge into the valve supply line at the pool equipment to ensure flow to the valve. Install a 2-way valve in the line to simplify valve maintenance.

Connect the water source from the pool pump to the valve inlet. Do not get glue in the valve housing as this will void the warranty. Tip: Do not turn valve upside down when gluing.

The valve is shipped with the top plate and removable pressure test plug pre-assembled and secured to factory torques. Do not loosen or remove these items prior to pressure testing.

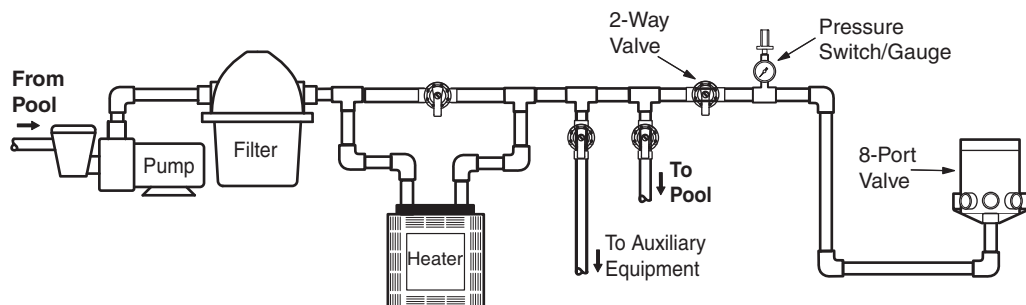

Discharge Lines

The **5-Port** valve uses 1 ½ in. pipe to conserve space. Use 2 in. reducer 90's to convert pipe rather than reducer bushings. Use a 3 in. stagger when cutting pipes to provide enough clearance for the reducers.

Connect PVC fittings directly to the 2 in. nipples on the **UltraFlex® 8-Port** valve. If Backer Rod (polyethylene foam) will be used to winterize the valve, 2 in. Sch. 40 tee fittings must be plumbed off each of the (8) outlet lines instead of 90° ell fittings. Glue a 2 in. female fitting adapter (spigot x female pipe thread) into the top outlet of the tee fitting and thread a 2 in. plug (male pipe thread) into the top of the tee. Extend the discharge lines down at least 24 in. below the freeze line.

Install the discharge lines from the valve in a stacked or flat configuration.

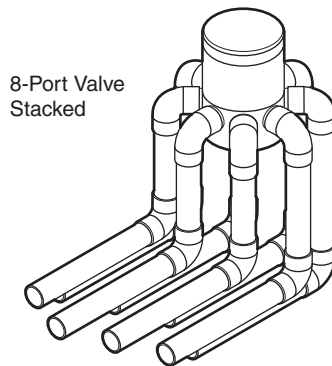

8-Port Valve
Stacked

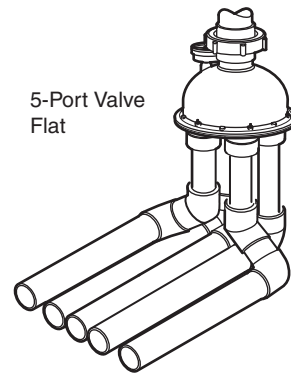

5-Port Valve
Flat

- Use heavy bodied PVC glue to connect PVC fittings to the valve housing. Do not get glue inside the housing as it will void the warranty.
- Install all lines with a minimum of 6 in. cover or in accordance with local codes.
- The distribution system is designed to rotate from shallow to deep. Port 1 will always be the step or bench port, followed by the shallow bank, etc. Looking down on the valve, it rotates clockwise. If a spa is included in the application, it will require a dedicated line from the valve. Follow the design plan to install the lines in the correct order.
- If all outlet ports on the valve are not needed, it is necessary to tie the unused port into an active port or **double port** the line. Customarily, double port lines to the hardest-to-clean area.

Consult the design plan for proper connections.

5-Port - When plumbing the valve, skip a port (ie. tie port #1 to port #3, not #2) when double porting.

UltraFlex 8-Port - Install a service-accessible check valve on both outlet ports to prevent reverse water flow. Skipping is unnecessary.

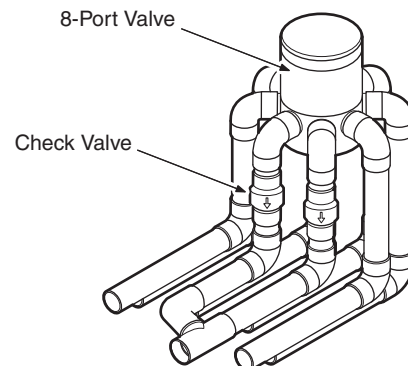

Auxiliary Equipment

Heaters

To compensate for heater system pressure drops, plumb heaters in a bypass line before the water valve. The heater bypass valve should be adjusted to $\frac{3}{4}$ open.

Chlorinators

In-floor systems can be used with erosion feeders, ozone generators and in-line salt converters. Consult manufactures instructions for proper installation to protect water valve and other pool equipment.

Automatic Pool Cleaners

When supplementing the in-floor system with a Zodiac automatic pool cleaner, plumb the dedicated cleaner line (booster pump if applicable) before the valve.

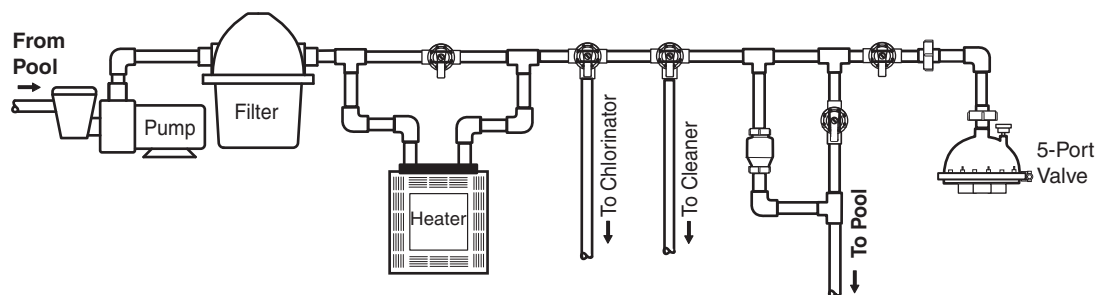

Pressure Testing

Pressure-test the system at a minimum of 35 psi or local code requirements. Keep the water valve secure and under pressure throughout the construction process.

Burial Cable for Electrical Hook-up of Controller (UltraFlex 8-Port only)

Since there is an open plumbing trench from the equipment to the water valve location, it is most convenient to complete the cable installation during the plumbing phase.

The electrical line from the controller to the valve must be the 18-gauge Burial Cable (part #1-9-182) as this cable has specific rating and certification for this product. For cable runs (i.e. electrical cable between controller and valve) in excess of 80 feet, contact Zodiac before wiring.

1. Reference Table 300 of the National Electric Code (NEC) for minimum burial depth requirements.
2. Leave excess wire (approximately 5 feet) at both the controller location and the valve location.

When all connections are complete and it is clear the system is holding pressure, backfill, tamp and level all trenches.

3

Installing Electrical Connections (UltraFlex 8-Port only)

Disconnect power supply before making any electrical connections. Refer to the wiring diagram (also located inside the controller) for complete details on all connections.

UltraFlex Controller

The controller can be connected to either a 120V or 240V power source, and hardwired or connected, using the appropriate plug, to a standard outlet protected with an approved cover.

- Mount controller on wall or vertical surface near the pool equipment
- Install flexible conduit to house the wiring
- Use no less than 12-gauge wire to make connections
- Use proper connectors and wire nuts to connect the transformer

Pressure Switch Connection

Connect the pressure switch, plumbed into the supply line, to the controller.

- Install flexible conduit to house the wiring
- Use no less than 18-gauge wire to make connection
- Use 18-22 gauge, fully insulated male push-on connectors at the switch
- Connect the pressure switch leads to the top terminal strip on the controller PCB

Valve Connection

If the plumber did not do the burial cable installation:

- The electrical line from the controller to the valve must be the 18-Gauge Burial Cable (part #1-9-182) as this cable has specific rating and certification for this product. For cable runs in excess of 80 feet, contact Zodiac for cable specifications before wiring.
- Reference NEC Table 300 for minimum burial depth requirements
- Connect the burial cable to the terminal strip on the motor mount plate at the valve, and to the bottom terminal strip on the PCB in the controller. Verify that the wire color sequence is the same at both locations.

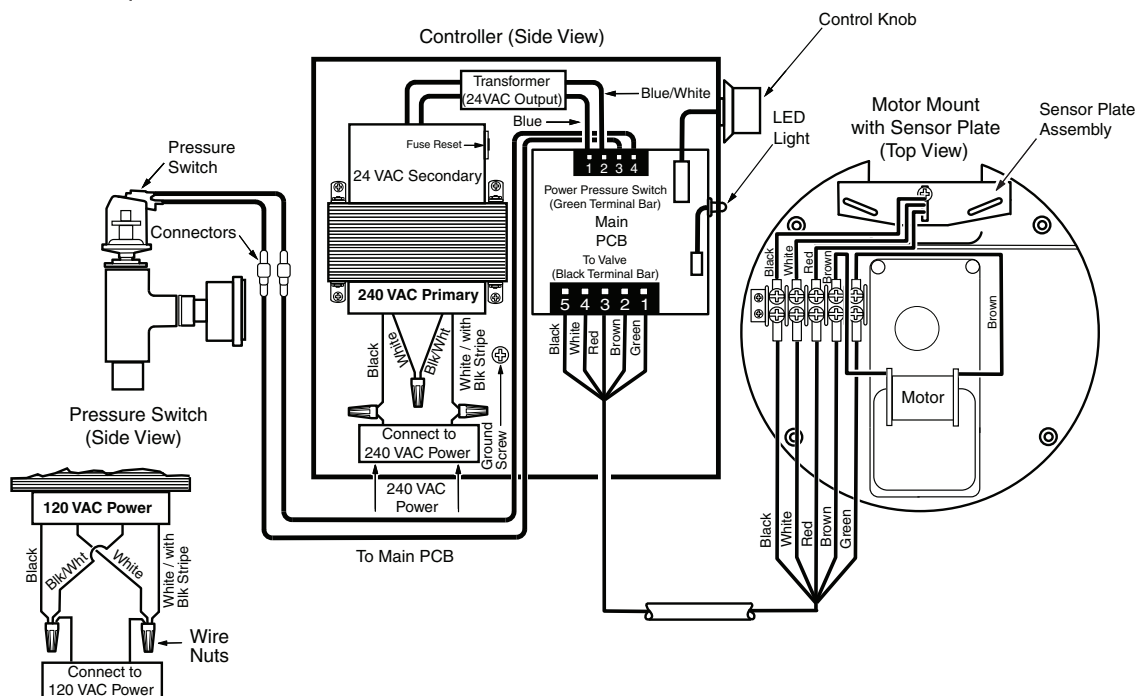

4

Preparing the System

Cut Cleaning Head Stub-ups and Clear Debris from System

After inspection, clear the system lines of debris using a combination of air and water.

1. Verify that the system is holding pressure (minimum of 35 psi), then relieve system pressure.
2. Use the UltraFlex® Collar Template (part #1-17-7) to cut each stub-up ensuring collars sit at a height to accommodate approximately ½ in. of final finish material.

Use a sander/grinder to sand each stub-up smooth and level with the shell finish to ensure proper glue adhesion with collar setting. Insert test plug in each stub up.

3. **UltraFlex 8-Port only:** Remove the screws securing the top plate and separate it from the valve. Attach the UltraFlex Blower Plate (part # 4-7-305) to valve housing.
4. Attach a blower assembly unit (blower, check valve, air/water supply and connectors; call Zodiac for assembly instructions) to the blower plate or directly to the union at the top of the 5-Port valve.
5. Turn on blower and water supply to fill the lines.
6. Starting at the cleaning head farthest from the valve, remove test plug and flush the pipe, blocking and releasing pressure several times to ensure a clear line. Replace test plug and repeat for each stub-up.

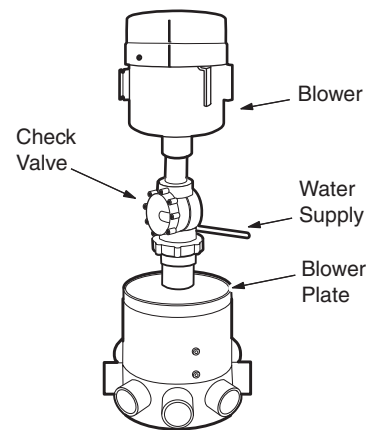

For Vinyl Liner Pools:

Set collar fittings before clearing lines.

1. Cut pipe stub-up flush with the pool floor. Then use an inside pipe cutter to cut it again 1 7/8 in. lower than the floor level.
2. Use ABS to PVC glue to secure the collar fitting. (Primer can be used on the pipe but not the fitting. Use glue on both.) Insert collar to a full stop to ensure proper height.
3. Excavate an area (12 in. around head and 8 in. below excavated floor) and fill with concrete to form a “thrust block” to eliminate movement of the cleaning head.
4. Clear lines and insert test plugs limiting water use as there is no solid pool bottom.

Install Cleaning Collars and Heads

When the pool interior is completely clean and ready for the final finish application, remove the test plugs to install the collars and cleaning heads. Reference design plan to verify color and nozzle size.

1. Use heavy bodied PVC glue to secure the cleaning collars. (Primer can be used on the stub-ups but not the collars. Use glue on both.)
2. Push collar firmly onto pipe.
3. Insert cleaning heads into collars.
4. Put blue protective caps on heads.

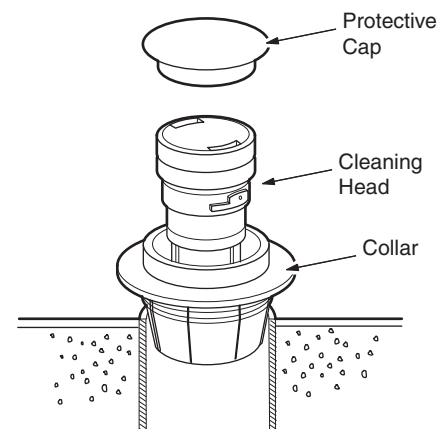

For Vinyl Liner Pools:

Pool liner must be in final position before installing collars and cleaning heads.

1. Press locking ring firmly into place in groove on collar fitting. **Installation Tip:** Turn collar upside down and use as a tool to press ring into place.
2. Use a razor knife to cut liner inside the locking ring, leaving at least a ¼ in. edge around the ring perimeter.
3. Tighten the collar into the collar fitting, turning clockwise until the collar lip fits snugly against locking ring.
4. Insert Metal Combination Tool (part #3-17-7) into collar and rotate clockwise until collar is firmly seated.
5. Install cleaning head in collar.

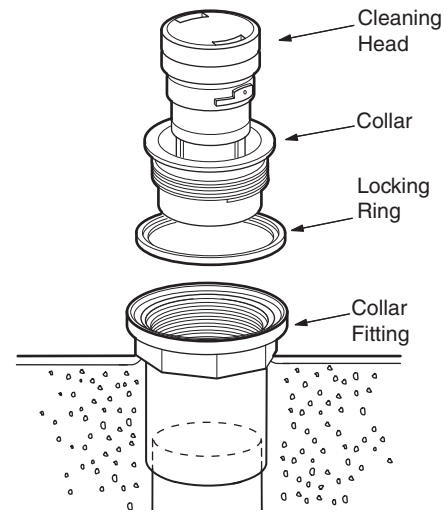
**Install Functional 5-Port Valve**

Remove the builder test housing and install the functional 5-Port valve.

1. Loosen V-clamp and union to remove the test housing.
2. Install the (5) small o-rings on the functional valve, wet them if necessary to help them stick but do not lubricate. Check positioning of large o-ring in groove of bottom plate.
3. Align guide pin and re-install V-clamp, tightening until band ends are about ¾ in. apart.
4. Position dome strainer (cone-up) and reconnect valve at union.

Install Internal Components of UltraFlex 8-Port Valve**Install the tee assembly.**

1. Remove the blower plate and make sure the housing is clear of debris.
2. Install the tee-assembly o-rings (shipped in lubricated bag) on the top of the tee and on the tee's inlet and outlet.
3. Place assembled tee in housing, securing tee at the inlet.
4. Insert the ½ in. Teflon® wear-bar into the slot on the side opposite the outlet.
5. Re-install o-ring and the top plate.

Install the motor assembly.

1. Remove the screws from the mounting stand-offs located on the top plate.
2. Insert the motor assembly onto the top plate and rotate until it engages with the tee assembly. The motor assembly plate will be flush with the top plate stand-off.
3. Align the mounting holes with the mounting stand offs and secure the motor assembly to the stand-offs.

The UltraFlex® 8-Port valve operates with a photocell for indexing. The valve lid must be in place for the valve to operate properly.

5 Starting the System

Before initiating the system, open a discharge line before the valve and flush the pool pump and filtration system. Clear debris from all filters and screens.

1. Verify proper water pressure to valve, optimum level is 15-25 psi.
2. **UltraFlex® 8-Port Only:** Check port alignment. Verify that system has discharge from only one valve outlet at a time and that pressure drops during valve rotation and increases when rotation is complete.

If adjustment is necessary:

- Verify secure installation of tee assembly.
- Loosen sensor plate screws, rotate plate clockwise 1/8 in. and retighten.

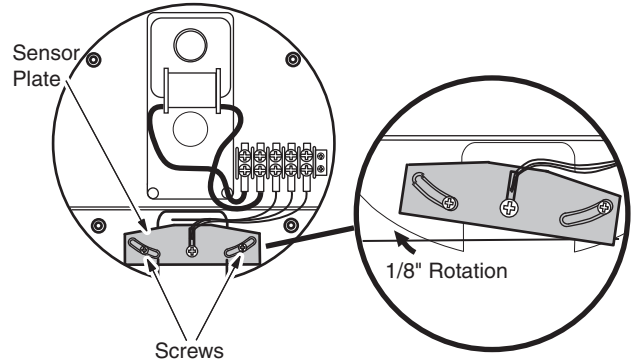

3. Confirm that all cleaning banks operate and that each head advances during pop-up and retraction.
4. **UltraFlex 8-Port Only:** The valve provides six operational timer options. Use these to increase coverage (leave valve in each zone for a longer period), increase rotation times or even pause the system.
 - Position 1: 15 seconds
 - Position 2: 30 seconds
 - Position 3: 45 seconds
 - Position 4: 60 seconds
 - Position 5: Pause mode
 - Position 6: Programmable (adjustable from 3 - 60 seconds)

Operation and Routine Maintenance

The Zodiac Caretaker cleaning heads are designed to operate at a specific gallonage and pressure. To maintain flow through the heads, run the system whenever the pump is on.

Cleaning times will vary according to application and environment. To determine the optimum cleaning time, run the system 24 hours a day to start. Reduce run times by two hours every two days until minimum cleaning time is determined. Six hours a day is recommended.

Cleaning the Filtration System

For optimum cleaning efficiency, routinely clean the pool pump basket, skimmer and filter screens. The 5-Port valve dome strainer should be checked for debris and cleaned periodically. Always reinstall the dome strainer in the cone-up position. Backwash the pool filter whenever pressure increases 3 psi above normal clean-filter operating pressure.

Changing Cleaning Heads

The cleaning head must be in the full down position before removal.

1. Attach the Head Removal Tool (part #3-17-7) to the pool pole.
2. Snap tool into the head.
3. Turn counter-clockwise to release head from collar.
4. Pull and lift head out of collar.

To reinstall, simply insert head into collar and turn clockwise to lock it into position.

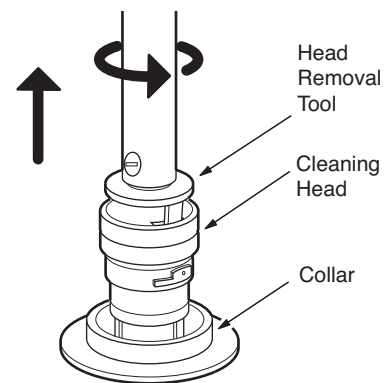

Winterizing

To prevent freeze damage in cooler climates, remove water from the outlet discharge lines above the freeze line and seal the valve.

5-Port

1. Remove water valve.
2. Remove any cleaning heads located above the freeze line (step or bench heads).
3. Use compressor or blower to blow water from discharge lines.
4. Place winterizing plug into collar.
5. Insert winterizing plugs into ports on bottom plate of valve.

UltraFlex 8-Port

There are three alternative methods to winterize the UltraFlex® valve:

Backer Rod Method: Uses (polyethylene foam) to winterize the valve and requires the installation of tee fittings at each outlet line of the valve.

Expansion Plug with Blow-Through Valve Method: Uses Rubber Tapered (Winterizing) Expansion Plugs with Blow-Thru Valves to seal system.

Standard Expansion Plug Method: Uses regular Rubber Tapered (Winterizing) Plugs to seal the system.

Before winterizing, disconnect the power/sensor cable from the terminal strip at the valve.

1. Remove the motor assembly, separate it from the top plate and store it in dry, protected location.

Expansion plug methods: Remove tee assembly and tee assembly o-rings. Place the o-rings in a plastic bag, and store them with the motor assembly.

2. Lower the water level of the pool to below the tile level.
3. Seal the valve.

Backer Rod method: Remove the 2 in. plugs from the tee plumbed on the (8) outlet lines of the valve. Place a 2 in. diameter section of Backer Rod (polyethylene foam) into the outlet line until it reaches the bottom of the plumbing line. (The plumbing line must extend a minimum of 24 in. below the freeze line.) Cut the foam level with the top of the tee fitting and thread the 2 in. Plug halfway onto the fitting.

Expansion plug methods: Using an air compressor/blower at the filter system, blow out the feed line to the valve. Place a #11 winterizing plug into the inlet line at the valve.

Expansion plug with blow thru valves:

Place # 9 ½ expansion plugs w/ blow thru valves into each outlet port inside the valve. Use an air compressor with an air chuck at the valve to blow out the outlet lines. Blow each line until air can be seen coming from the line in the pool/spa floor.

Standard expansion plug: Use an air compressor or 2 ½ hp spa blower with an adapter to blow out the outlet lines at the valve until air can be seen coming from the line in the pool/spa floor. Place a # 9 ½ expansion plug into the each outlet port.

4. If cleaning heads are located above the freeze line (i.e. steps, benches, etc.) remove the heads and seal the lines.

Backer Rod method: Push 1 ½ in. diameter foam into the collar until it reaches the bottom of the plumbing line below the pool/spa. Place a # 10 ½ (2 in. Pipe) Rubber Tapered Expansion (Winterizing) Plug into the collar.

Expansion plug methods: Use the air compressor to blow out the line and place a #10 ½ expansion plug into the collar.

5. Reinstall the top plate and the valve cover (test housing cover if available) for the winter season.

At spring startup, apply lubricant to the motor assembly drive shaft before inserting it into the top plate receptacle.

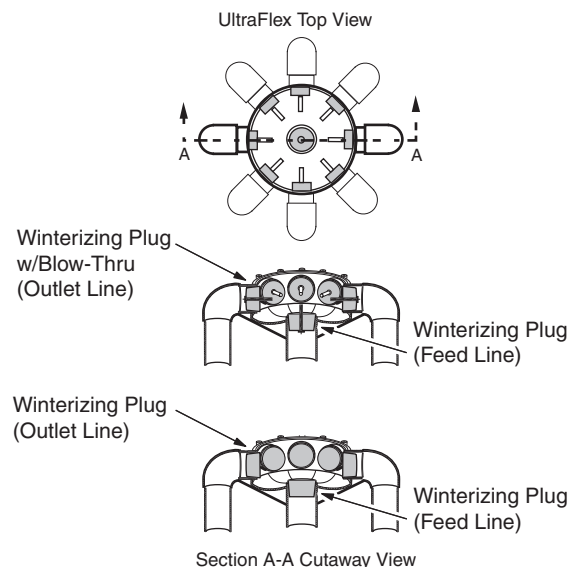
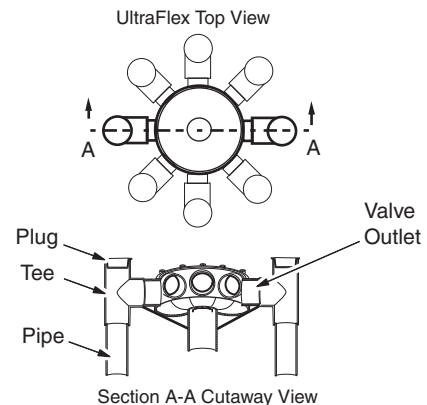

Troubleshooting

If the Zodiac Caretaker cleaning system displays the following actions, adjustments may be necessary to restore performance. Refer to exploded parts diagram for part references.

Action: Dirty spots appear.

- Solution:
1. Clean the pool filter, pump basket, skimmer baskets and if 5-Port valve, the valve dome strainer.
 2. Make sure all auxiliary valves (surface returns, waterfall, spa overflow, etc.) are closed.

Action: Dirt is trapped between heads.

- Solution:
1. Verify that the heads on each side of dirt are pointed in the same direction. Advance a head, if necessary, using the head removal tool to ratchet the head up and down until nozzle points in the correct direction.
 2. Increase the cleaning time. If using the UltraFlex valve, increase run-time to 60 seconds.

Action: Cleaning head advances, but is not cleaning.

- Solution:
1. Check for debris lodged in the nozzle.

Remove the head from the collar. Run the pump for two full cycles on problem bank. Recheck for particles in the cleaning head nozzle and re-insert the cleaning head.

Action: Cleaning head will not pop up or does not go down.

- Solution:
1. Remove the head. Inspect the cleaning head and collar for plaster remnants or debris.
 2. With system running on the problem bank and lightly depress the problem head a using telescoping pool pole.

Action: Pressure is lower than normal.

- Solution:
1. Clean the pool filter, pump basket, skimmer baskets and if 5-Port valve, the valve dome strainer. Backwash the pool filter.
 2. Make sure all auxiliary valves (surface returns, waterfall, spa overflow, etc.) are closed.
 3. Confirm that the pool pump is operating normally.
 4. Check for leaking or worn o-rings. Replace if necessary.

Action: The 5-Port valve does not cycle.

- Solution:
1. Clean the pool filter, pump basket, skimmer baskets and valve dome strainer. Backwash pool filter if necessary.
 2. Make sure all auxiliary valves (surface returns, waterfall, spa overflow, etc.) are closed.
 3. Turn pump on and off several times to clear system.
 4. Remove valve, turn upside down, and spray pressurized water up into the valve.

Action: The UltraFlex valve does not cycle.

- Solution:
1. Make sure water is properly routed to the valve; all auxiliary valves (surface returns, waterfall, spa overflow, etc.) should be closed.
 2. Verify that the valve is not in pause mode.
 3. Make sure GFI is not tripped and check the main power source connections.
 4. Check pressure switch wiring connections.
 5. Verify that terminal pin number (ex: pin #1-5) and wire color sequence match on both ends of electrical connections.
 6. If the red indicator LED remains on but the valve is not rotating, check under the top plate for mechanical restrictions like debris or a damaged o-ring.

Action: Two of the UltraFlex ports are discharging water at the same time.

- Solution:
1. Check for proper port alignment at the valve.

Action: UltraFlex valve does not pause at an outlet port.

1. Verify that valve cover is properly in place.
2. Replace defective or damaged sensor (part #3-7-6).

Action: UltraFlex valve is leaking.

1. Check for debris underneath the top plate (#4) or around the face seal o-ring (#5) and clean as necessary.
2. Verify that top plate is tight. Replace the o-ring if necessary.
3. Shaft seal is leaking, replace.

To replace the 5-Port water valve:

1. Unscrew the two union nuts and remove the pipe section located in front of the water valve.
2. Use a 7/16 in. deep socket with a ratchet or a 7/16 in. wrench to loosen and remove the V-clamp.
3. Lift water valve straight up to remove.
4. Remove the five small o-rings, the large o-ring, the union o-ring, and the dome strainer. If the system is over one year old, replace the o-rings (O-Ring Kit, part #5-13-1).
5. Place the five small o-rings on the bottom of the replacement valve. Wet them to help them stick; do not use lubricants.
6. Place the large o-ring in the groove provided in the bottom plate.
7. Locate the alignment pin and align it with the hole on the bottom plate.
8. Place the V-clamp around the valve and tighten (tap perimeter periodically to ensure equal tension) until the band ends are about $\frac{3}{4}$ in. apart.
9. Reinstall the dome strainer, dome up. Replace connecting pipe section and tighten unions securely.
10. Turn on system and check for leaks.

Exploded Parts Diagram 5-Port Valve

No.	Part #	Description	Qty
1	5-13-1	O-Ring Kit	1
2	1-1-216	Stainless Steel Dome Strainer	1
3	3-9-201	Top Housing	1
4	1-3-1	Pressure Gauge	1
5	5-9-2001	Rebuild Kit	1
6	1-9-214	Valve Center Plate	1
7	3-9-216	V-Clamp with Nut	1
8	1-9-215	Bottom Plate	1
9	1-1-220	Pressure Relief Valve	1
10	4-1-2002	Union Complete	2

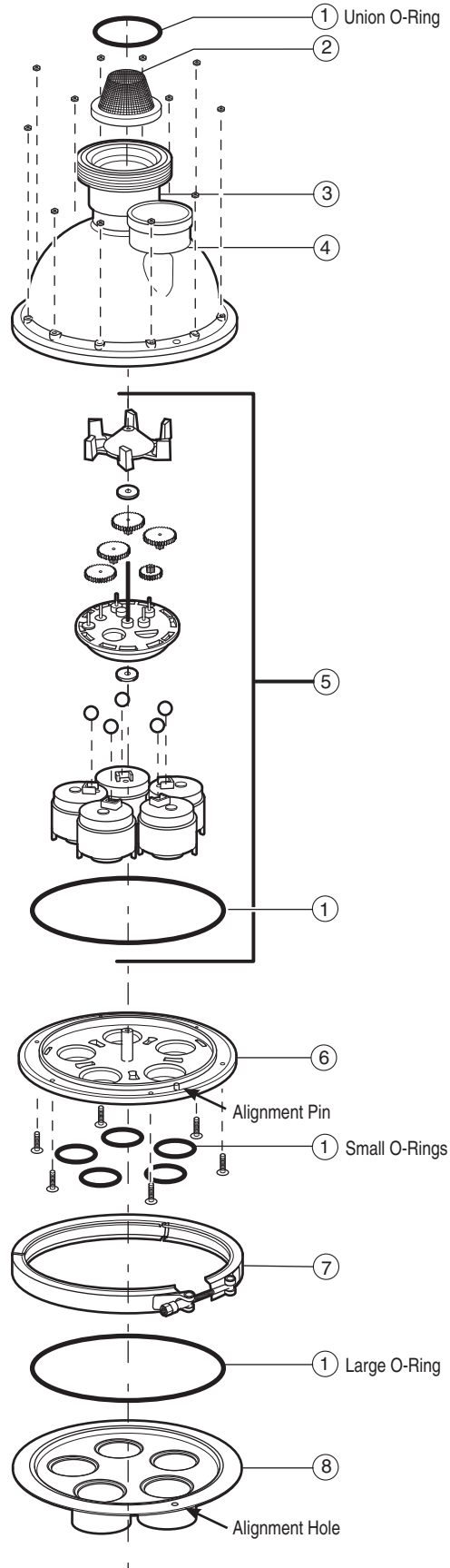
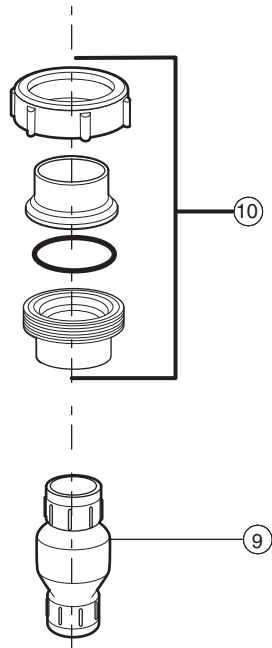

Exploded Parts Diagram

UltraFlex 8-Port Valve

No.	Part #	Description	Qty
1	3-7-8	Valve Lid	1
2	3-7-5	Motor Assembly	1
3	3-7-6	Sensor Plate	1
4	3-7-12	Top Plate Assembly	1
5	1-13-15	O-Ring, Face Seal	1
6	3-7-3	Tee Assembly	1
7	4-7-4	O-Ring Kit	1
8	2-7-53	Inlet Wear Insert	1
9	4-7-2	Pressure Switch/Gauge Assembly	1
10	4-7-200	Plumbing Kit	1
11	4-7-202	Controller	1
12	4-9-189	Motor/Sensor Terminal Strip	1

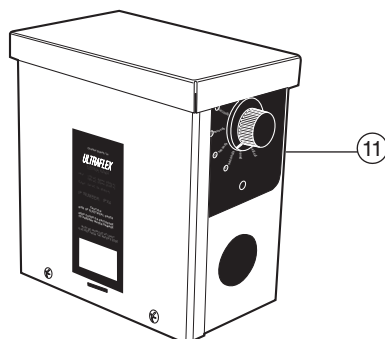
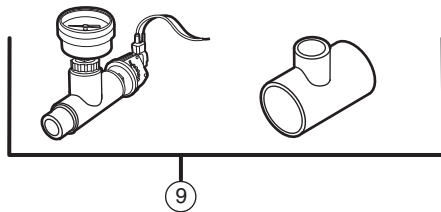
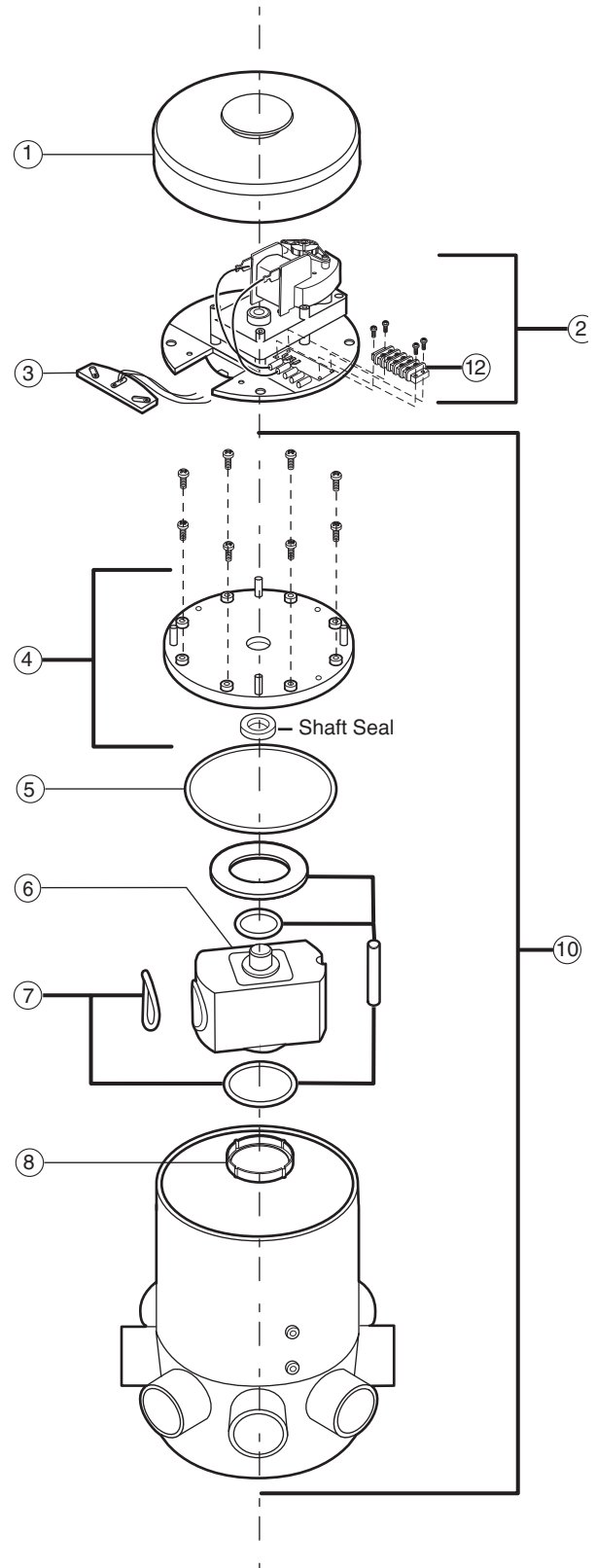

Notes

Notes

Zodiac Pool Systems, Inc.
2620 Commerce Way, Vista, CA 92081
1.800.822.7933 | www.ZodiacPoolSystems.com

*ZODIAC® is a registered trademark of Zodiac International, S.A.S.U., used under license.
All trademarks referenced herein are the property of their respective owners.*

©2011 Zodiac Pool Systems, Inc. TL-1300 Rev. A 1103

